

STOP GATES

Waterman Stop Gates can be fitted with either rod handles or a slot grip for hand placing. Guide rails for embedded, flatback or channel mounting are available.

These gates are designed for a maximum head of one foot over the slide, unless otherwise specified and are used generally in diversion applications.

Options available include "J" Bulb seals for minimum leakage, ultra high molecular weight polyethylene seats for increased ease of operation and special cut outs such as "V" notch or slot openings for water measurement.

All frames feature welded construction. Slides are minimum $\frac{1}{4}$ " thick to minimize deflection and contribute to long gate life.

Available in an almost unlimited range of sizes and configurations, Waterman stop gates can be manufactured from aluminum, steel, stainless steel or fiberglass.

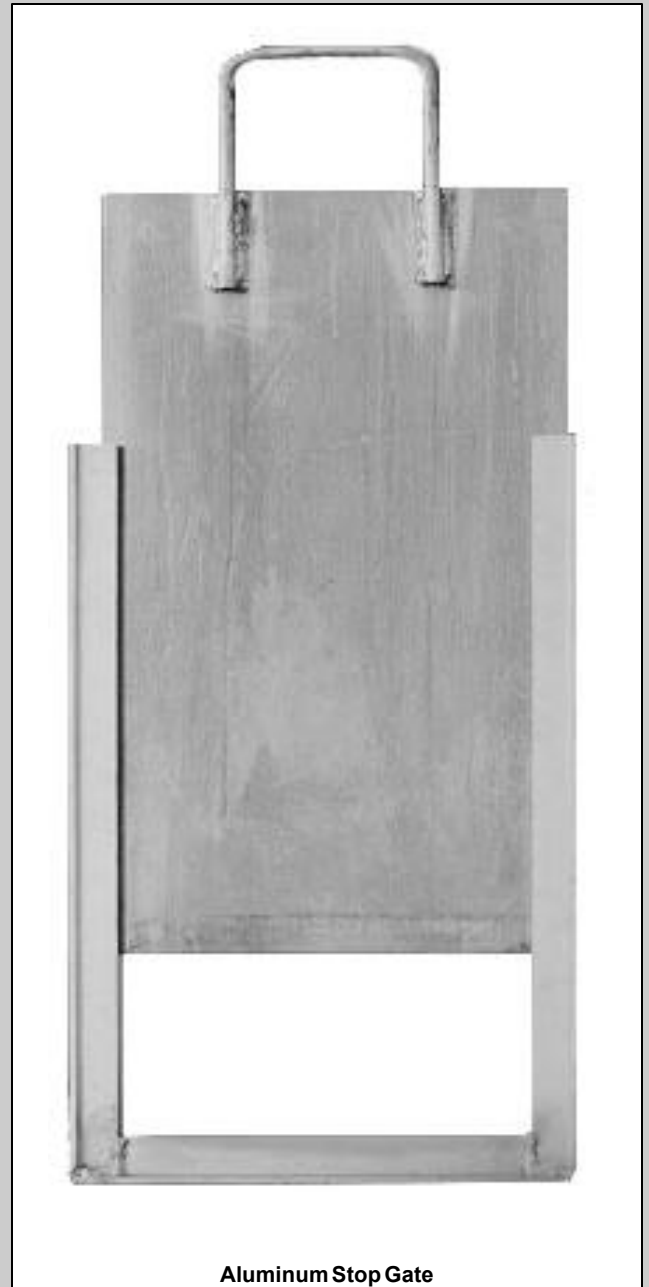

Aluminum Stop Gate

TYPICAL SPECIFICATIONS ALUMINUM STOP GATES

Guides

The gate frame shall be a rigid, welded unit with a clear opening the same size as the waterway, unless otherwise specified. The guides shall be of structural or stainless steel shapes or aluminum extrusions. The guides will be of the length specified.

Additional members will be added to the frame as required for flushbottom closure, spigots, and "J" Bulb seals.

Slide

The slide shall be plate reinforced with structural shapes welded to the plate. The slide shall not deflect more than 1/360 of the span of the gate under maximum head.

Flushbottom Closure

When indicated on the plans or in the gate schedule, gates shall be furnished with a flush seal arrangement. A resilient neoprene seal shall be securely attached to the frame along the invert, and shall extend to the depth of the guide groove.

"J" Bulb Seals

When an unseating head is shown on the plans, or specified in the gate schedule, the gate shall be provided with "J" Bulb seals along the sides of the gate. Seals shall be mounted either on the frame or slide, such that seals do not protrude into the specified opening of the gate.

(Optional). Gates shall be furnished complete with ultra high molecular weight (U.H.M.W.) polymer seats which contact the slide face.

For steel and stainless steel gates, ultra high molecular weight bearing strips shall be mechanically retained to lock seat in place. For aluminum gates, strips shall be installed in dovetail grooves in the extruded frame.

Material

Frames and Slides

- Mild steel - ASTM A-36, or
- Stainless Steel - ASTM A-276, Type 304 or 316 as specified
- Aluminum - ASTM B-209 and B-211 alloy 6061-T6

Fasteners and Anchor Bolts

- Steel - ASTM A-307 Galvanized per ASTM A-153, or
- Stainless Steel - ASTM A-276, Type 304 or 316, or
- Stainless Steel - ASTM A-193 18-8, as specified

Flushbottom Seals and "J" Bulb Seals

- Rubber - ASTM D-2000 BC 610/615 or other suitable composition for extended use in water and sewage

Finish

- Manufacturer's Standard Paint on mild steel
- Optional - Galvanize per ASTM A-123
- Mill finish on all aluminum and stainless steel

ALUMINUM STOP GATE

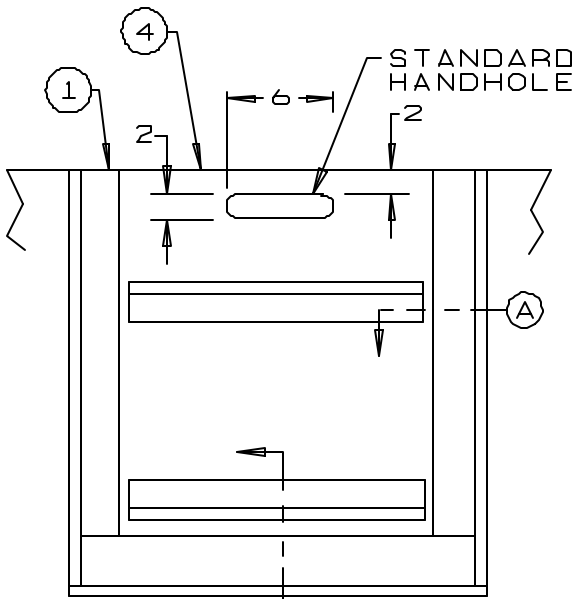

EMBEDDED TYPE

A 1

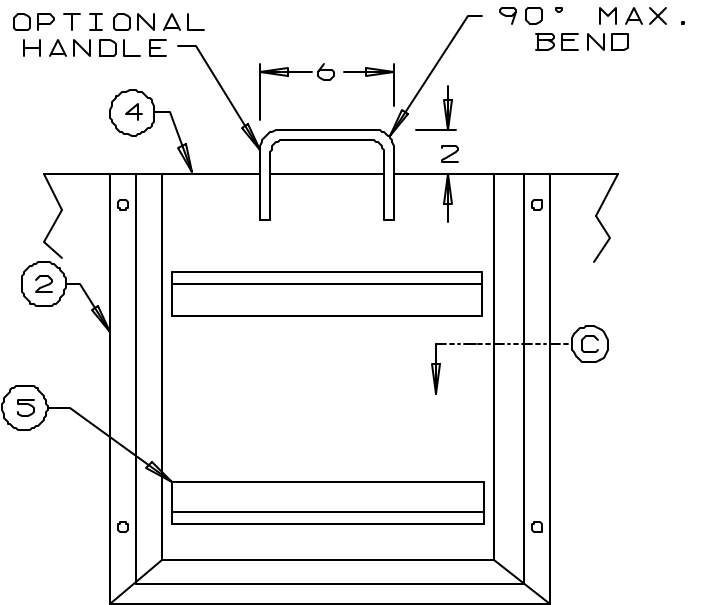

SURFACE MOUNT TYPE

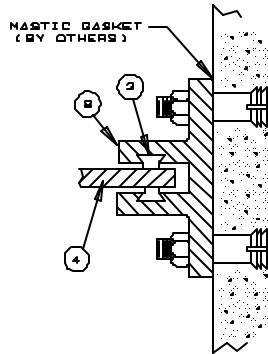
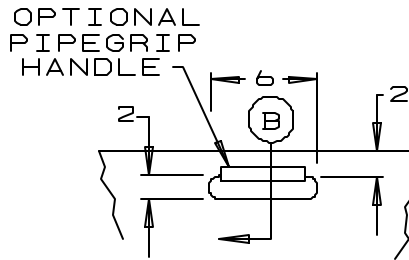
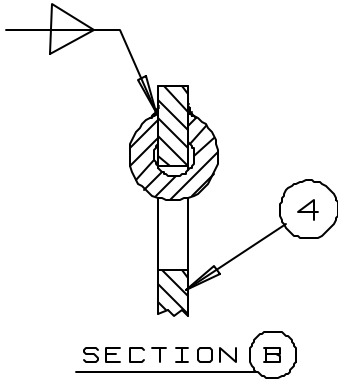

ALTERNATE SECTION A
(CHANNEL MOUNTED)

PARTS	
NO.	NAME
1	GUIDERAIL
2	GUIDERAIL
3	BEARING STRIP
4	SLIDE
5	STRONGRIB
6	ANCHOR BOLT w/NUT
7	FLUSHBOTTOM SEAL
8	GUIDERAIL

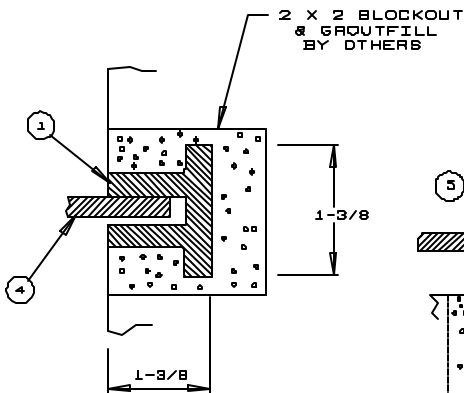

SECTION A

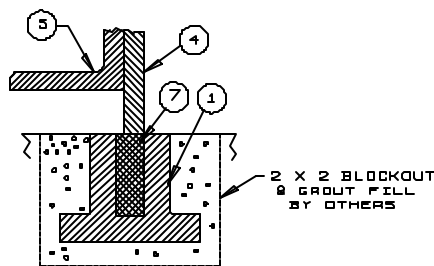

SECTION A1

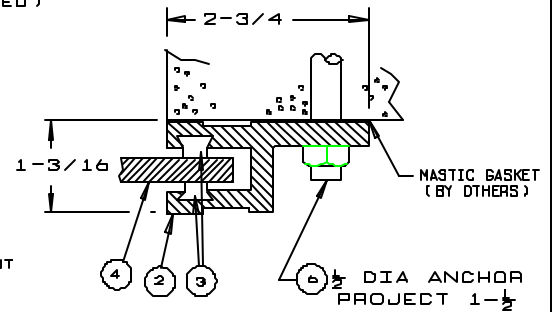

SECTION C