

PC-150 SPLIT DISC CHECK VALVE

- FUSION EPOXY COATED
- EFFICIENT LINE OPERATION
- 150 PSI SERVICE
- SHOCK RESISTANT
- QUALITY MATERIALS
- AVAILABLE IN 4", 6", 8", 10", AND 12" SIZES

USES:

The Waterman PC-150 split disc Check Valve is rated for working pressures to 150 psi. It complements the Waterman check valve line by adding a higher pressure valve to existing models.

FEATURES:

The valve body is of fusion epoxy coated cast iron construction and is belled to allow maximum flow around the seat ring and disc, minimizing head loss.

The replaceable seat ring section is of flat seat design constructed of fusion epoxy coated cast iron with Buna-N rubber vulcanized to the seat face for a positive seal when the flap cover is in the closed position.

The disc is split type and spring loaded to create a positive quick closure of each disc half. The springs are retained in position with a stainless steel rod.

Simplicity of design allows the valve to be placed easily in pipelines and allows for quick replacement of parts when required.

The PC-150 Check Valve will provide for long uninterrupted use under varying conditions.

Thickness (flange to flange)

- 4" model = 3.00 inches
- 6" model = 3.44 inches
- 8" model = 4.06 inches
- 10" model = 4.75 inches
- 12" model = 5.25 inches

PARTS LIST		
No.	Name	Qty.
1	Body	1
2	Seat Ring	1
3	Flat Head Screw	4
4	Disc	1
5	Spring	1
6	Rod	1
7	Pipe Plug	1
8	Spacer	3

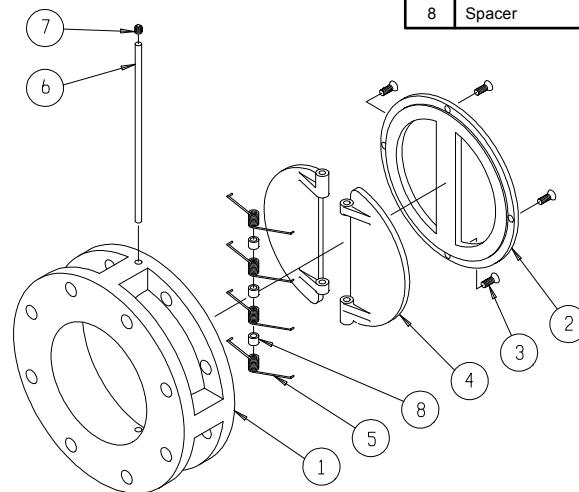
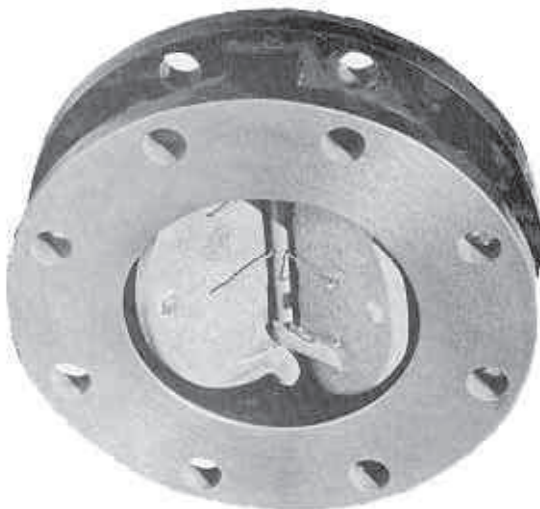

MODEL PC-150 SPLIT DISC CHECK VALVE

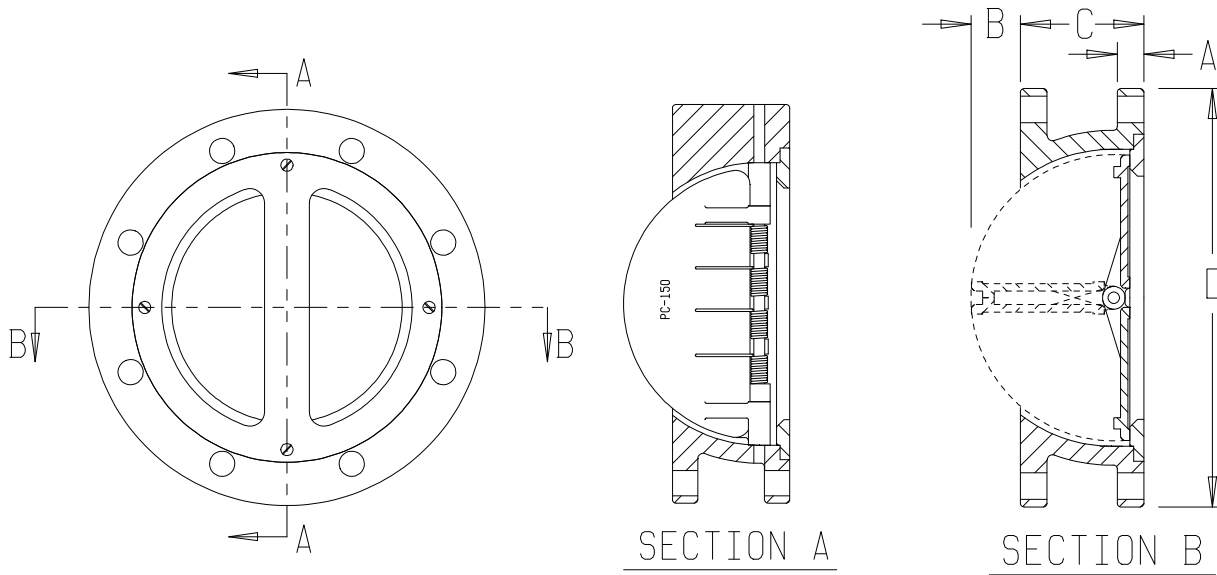

SIZE	DIMENSIONS				
	4"	6"	8"	10"	12"
A. FLANGE THICKNESS	.68	.75	.88	1.18	1.25
B. EXTRA CLEARANCE FOR DISC	.68	1.25	1.62	2.25	3.00
C. BODY WIDTH	3.00	3.44	4.06	4.75	5.25
D. FLANGE OUTSIDE DIAMETER	9.00	11.00	13.50	16.00	
ALL CIRCLES ARE STANDARD 125# DRILLING PATTERN - STRADDLE CENTER LINE					

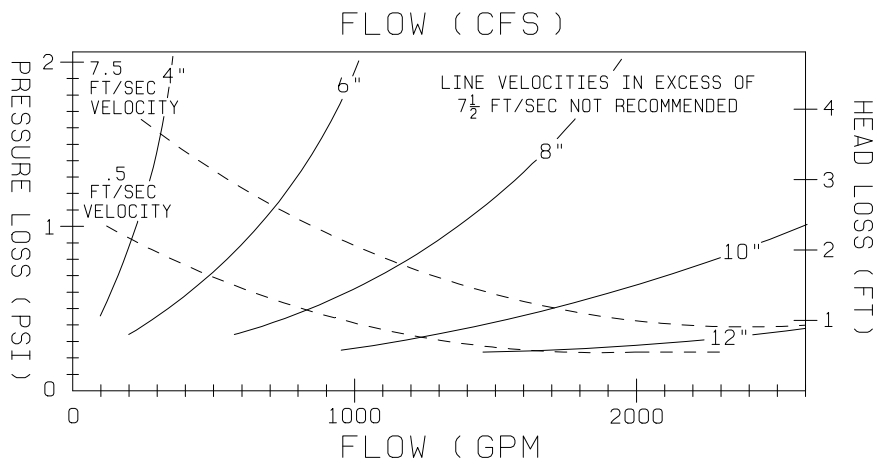

**NOTE: For preliminary design purposes only.
Ratings may vary under actual working conditions.**