

DISTRIBUTORS

FREE SURFACE WATER DISTRIBUTION AT A CONSTANT ADJUSTABLE FLOW

Waterman distributors are a form of free surface turnout equipment designed to **supply controllable constant flows**.

The flow is set to any required value by opening or closing the requisite combination of different-sized shutters. Once the distributor is locked at a given setting, the flow remains constant **even though the upstream and downstream water levels may vary to some extent**.

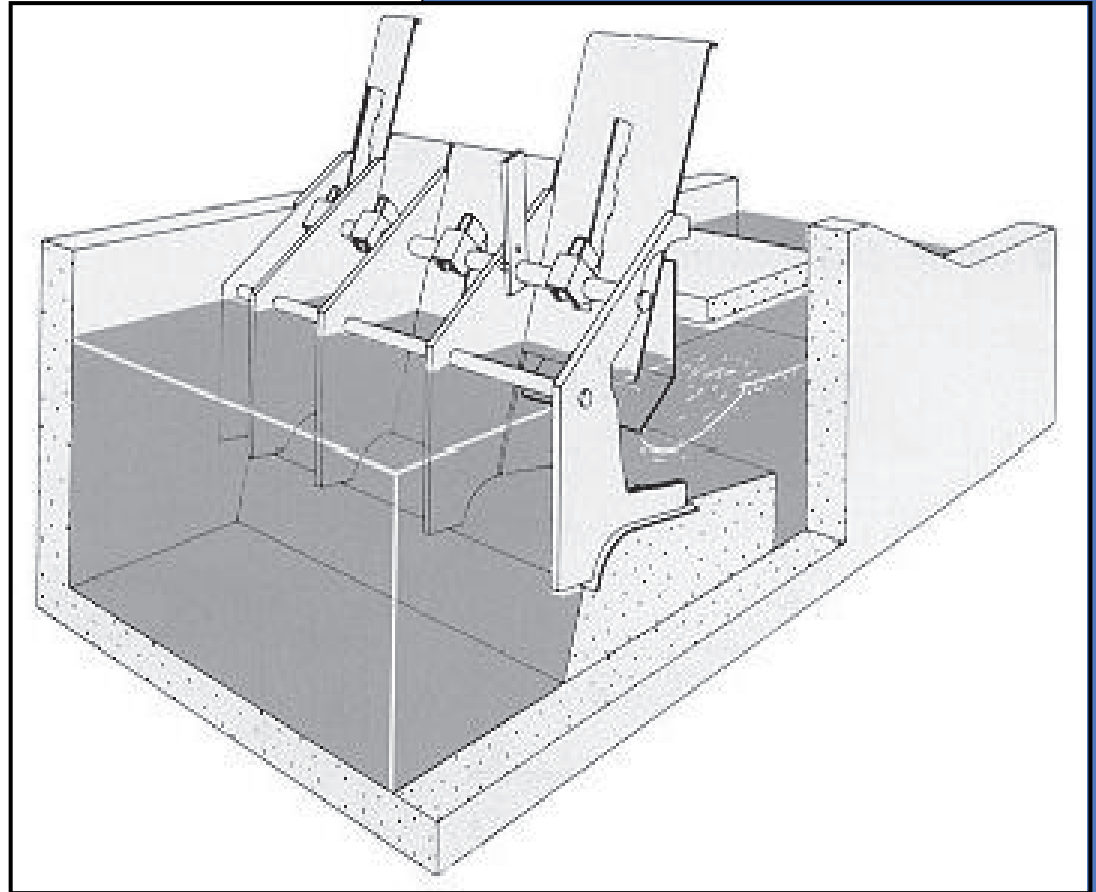

Battery of distributors DL, 1700 l/s
(one 1000 l/s unit + one 700 l/s unit).

WORKING PRINCIPLE

The practically constant flows supplied by these distributors are obtained without any moving parts. The combination of a specially-shaped sill with a fixed baffle plate above it corrects any effect a rise in the upstream level may have upon the flow. At low upstream levels, the sill operates at free surface flow conditions (fig. 1, phase A) the level rises, the water above the sill finally reaches the bottom edge of the baffle plate, the sill and baffle then act as an orifice with a corresponding sharp reduction in the discharge coefficient and contraction of the jet (phase B). The jet contraction tends to become more pronounced as the head increases still further, thus reducing the corresponding flow variation accordingly (phase C).

As figure 1 shows, the flow through the distributor can be maintained very near its nominal value over a wide range of upstream level conditions. The permissible level ranges are also shown for the following flow conditions:

- a) For a flow varying by $\pm 5\%$
- b) For a flow varying by $\pm 10\%$ with respect to its nominal value.

The above ranges can be increased quite appreciably by fitting an additional baffle downstream of the first. Owing to the contraction of the jet discharging from the first baffle, the second baffle can be fitted nearer the sill so as to form a smaller orifice (Fig. 2, phase B).

As the upstream level rises above a certain height, the first baffle is submerged, the second baffle then comes into action, and the flow's tendency to increase is restrained still further. The various distributor components are designed and arranged to achieve a maximum correcting effect.

All other things being equal, the permissible level variation for a flow variation of $\pm 5\%$ about the nominal value is 190% greater with these distributors than with the single baffle design, and 150% greater for a $\pm 10\%$ variation. The water level discharge relationship curve for the equipment is shown in Figure 2.

Figure 1

Diagrammatic layout and operating curve for single baffle distributors.

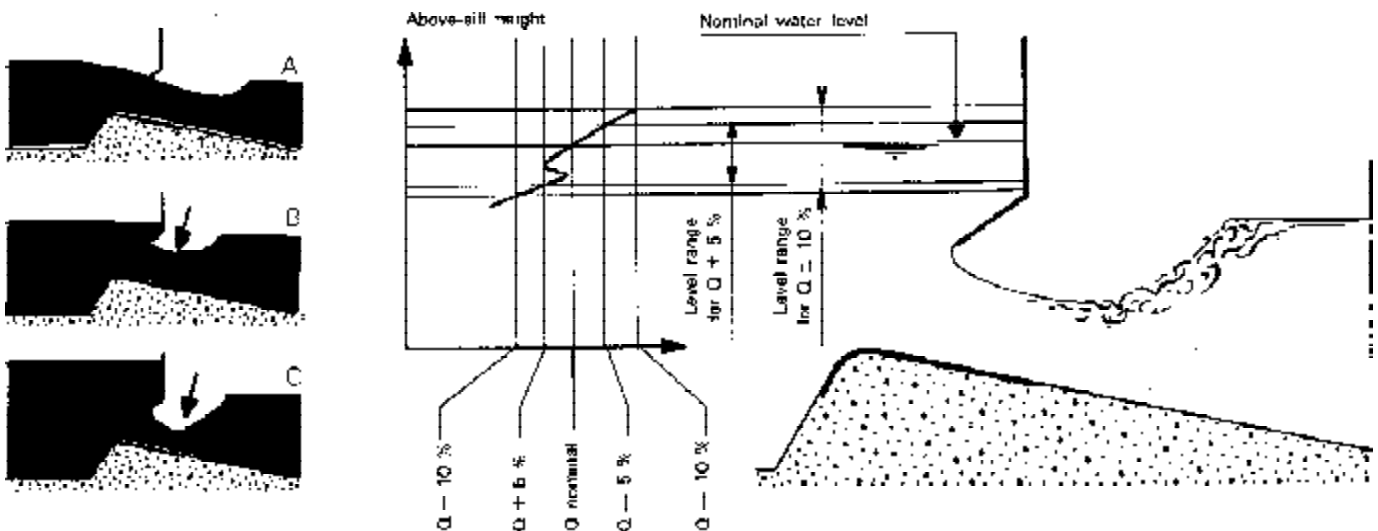

Furthermore, the flow from the distributor is not affected by downstream level variations, for the downstream slope of the sill is so designed as to produce supercritical flow conditions, and hence a hydraulic discontinuity. Owing to the formation of a hydraulic jump, however, the

potential energy of the flow is recovered, thus keeping the head losses through the distributor low. The minimum head loss quoted further on occurs as the hydraulic jump moves upstream towards the baffles.

DESCRIPTION

Waterman distributors are unit construction metal assemblies which, if set at the correct height in suitable concrete structures, provide a highly efficient form of water turnout equipment.

Four series are available, differing by the dimensions of their longitudinal sections and identified in terms of nominal flow per unit width:

Series DX	:	10 l/s/dm
Series DXX	:	20 l/s/dm
Series DL	:	50 l/s/dm
Series DC	:	100 l/s/dm

The series letters DX, DXX, DL, and DC are given an index 1 or 2, denoting single and double-baffle types respectively.

The flow staggering is as follows:

- Series DX (fitted with 5, 10, 15 and 30 l/s shutters): in steps of 5 l/s.
- Series DXX (fitted with 10, 20, 30, 60 and 90 l/s shutters): in steps of 10 l/s.
- Series DL (fitted with 50, 100, 200 and 400 l/s shutters): in steps of 50 l/s.
- Series DC (fitted with 100, 200, 400, 600 and 1000 l/s shutters): in steps of 100 l/s.

Distributors with special staggering (e.g. with single shutter for small units or with non-standard shutters), can be supplied on special request.

In order to standardize the equipment, the smaller sluices have been placed on the left bank side. The leading longitudinal section dimensions of these distributors are

summed up in the Standard Dimensions table on page 60 and the Standard Sizes table on page 61 lists the nominal flows and corresponding widths for each series.

The shutters are arranged side-by-side in a row and normally remain either fully open or fully closed. Each shutter is held in position by a special stirrup, all the stirrups being locked by means of a single lever once the required flow combination has been set. **This very simple arrangement prevents the distributor setting from being tampered with by unauthorized persons.** Furthermore, as a result of the hydraulic features of the equipment (see above), network users are unable to affect the flow by deliberately altering the water level. In other words, these distributors provide a particularly reliable form of control.

Series DC distributors may, however, lead to excessive widths in very large installations. This difficulty can be overcome by building up composite Series DCC distributors (200 l/s/dm), consisting of metal baffles fixed above a concrete still of special profile, the individual sluices being controlled by independent sliding gates. In this particular Series (fitted with 1, 2, 4 and 5 m³/s gates), the separating walls between the sluices take the form of concrete piers, and the flow can be adjusted in steps of 1 m³/s.

The hydraulic characteristics of this fifth series of distributors are also shown in the table on page 61, as indications only.

Figure 2

Diagrammatic layout and operating curve for double baffle distributors.

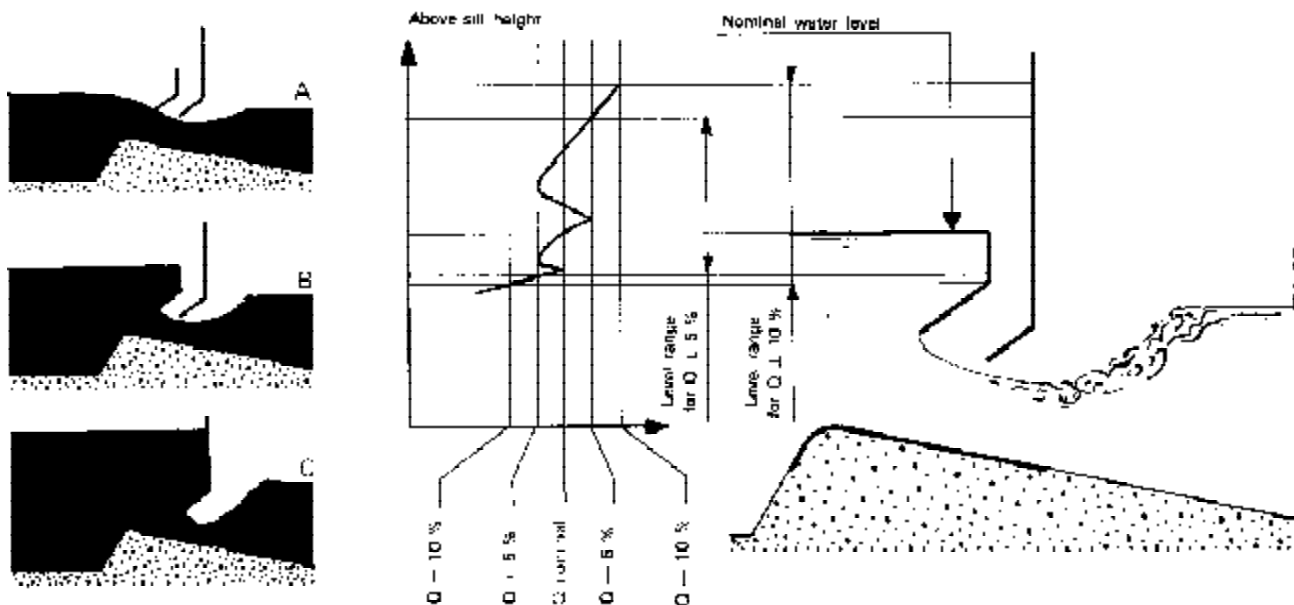

CONSTRUCTION

The unit-construction distributors are welded steel plate and section assemblies protected against corrosion by a hot-sprayed zinc metallization process and coats of primer and glycerophthallic paint.

Series DX and DXX distributors are fitted with flat shutters sliding in grooves milled in the partition plates. Series DL and DC distributors are fitted with hinge mounted sector-type shutters so as to reduce the operating forces required to overcome the comparatively high water load acting upon them. These shutters are fitted with flexible brass or neoprene seals.

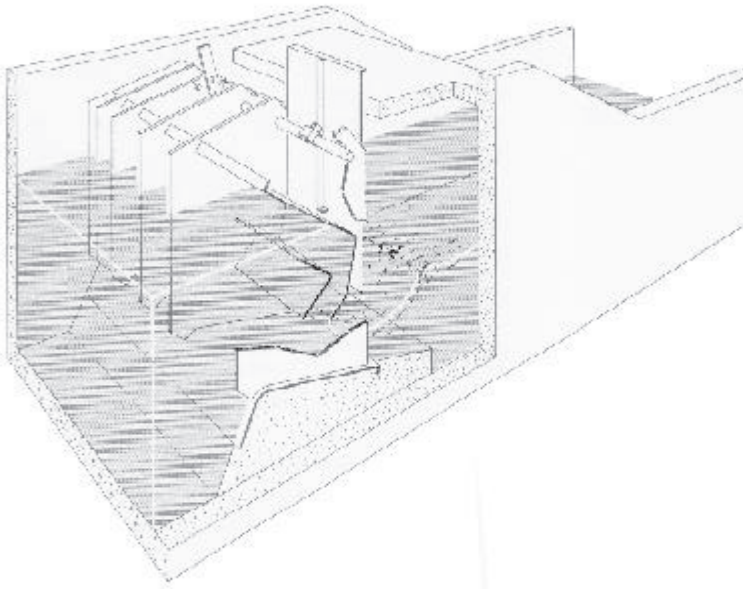

Figure 3
Type DXX₂-150
double baffle distributor

Note: The concrete walkway, shown for reference, is not absolutely essential for operating the distributors less than 1 meter in width.

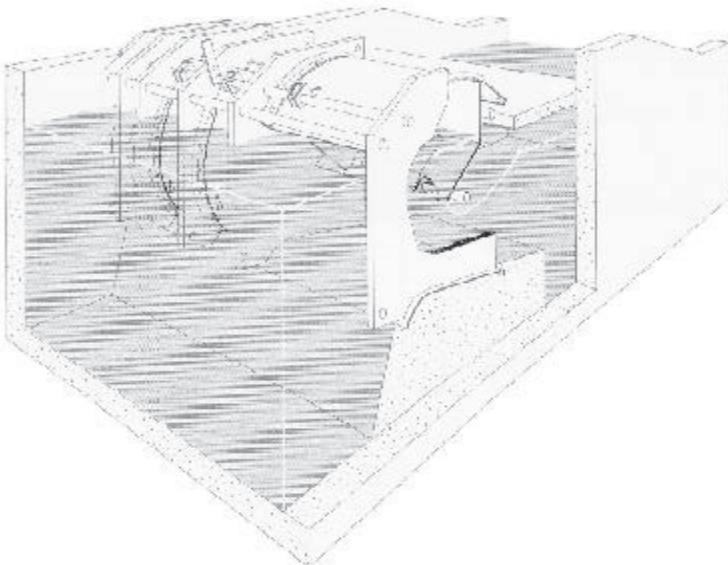
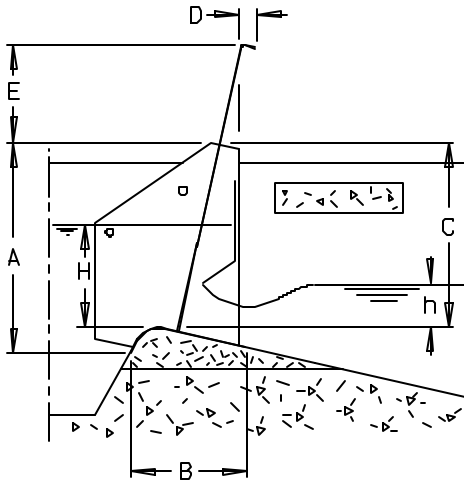
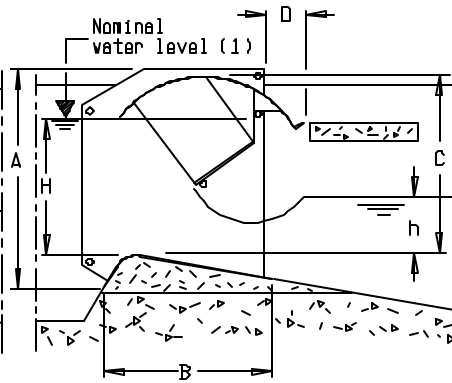

Figure 4
Type DL₁-500 single baffle distributor

STANDARD DIMENSIONS



TYPES DX₁ and DXX₁



TYPE DL₁

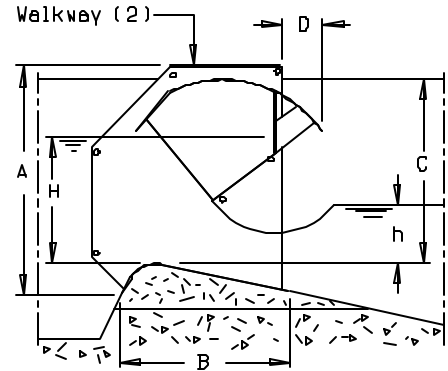

TYPE DC₁

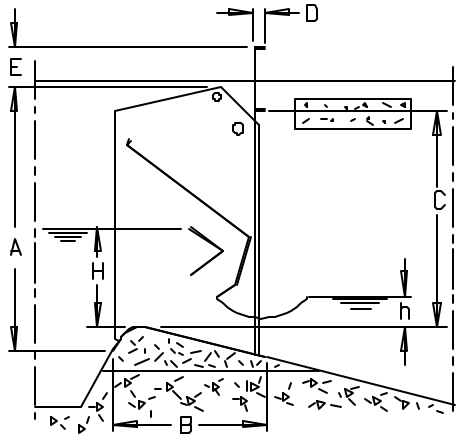

TYPES DX₂ and DXX₂

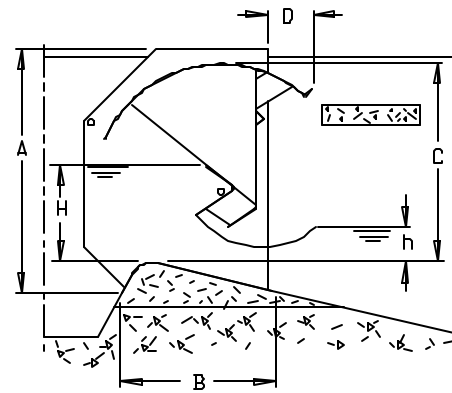

TYPE DL₂

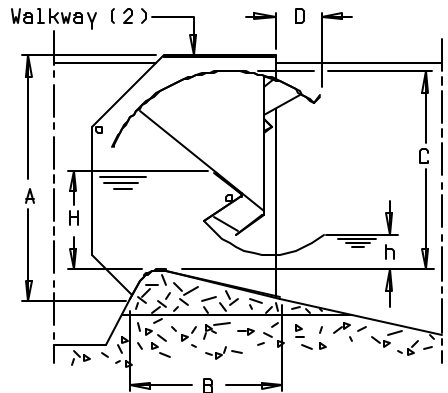

TYPE DC₂

Dimensions in centimeters									
DISTRIBUTOR	A	B	C	D	E	Working sill length at 100 l/s	H nom.	h (2)	Overflow level above sill
DX1	40	26	35	2	14	100	17	8 (10,5)	32
DXX1	65	38	58	4	22	50	27	12 (16,5)	51
DL1	88	77	72	16		20	50	22 (31)	68
DC1	144	122	116	25		10	79	35 (49)	109
DX2	47	27	36	2	8	100	17,5	8 (11)	35
DXX2	66	43	54	2	15	50	28	12 (17)	51
DL2	133	97	110	20		20	51	22 (31)	95
DC2	205	152	180	28		10	81	35 (50)	147

(1) See Note (1) on page 66 "masonry structure".

(2) See Note (2) on page 66 "masonry structure".

(3) The bracketed figures are suitable providing the upstream level never falls below the nominal level.

STANDARD UNITS

The distributor unit is identified by the series symbol followed by the nominal flow, e.g. "DXX₁-120" distributor.

Type DXX₁-120 single baffle distributor set to 70 l/s.

Note: As shown, the smaller sluices are always on the left bank side.
"I" is the width between the side plates, i.e. the width of the sluice

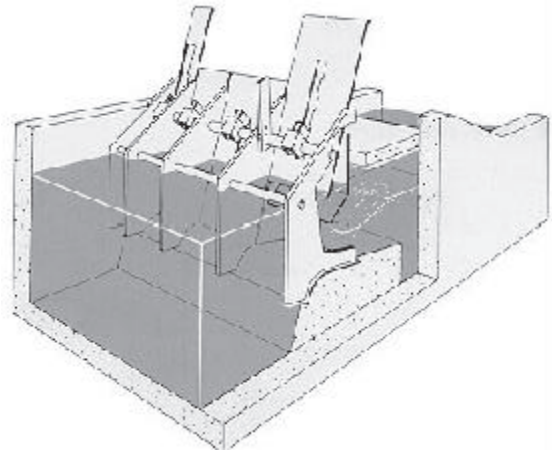

Types DX₁ and DX₂

NOMINAL FLOW l/s	NUMBER OF SHUTTERS				I cm
	5 l/s	10 l/s	15 l/s	30 l/s	
30	1	1	1		32
60	1	1	1	1	63
90	1	1	1	2	94
120	1	1	1	3	125
150	1	1	1	4	156

Types DXX₁ and DXX₂

NOMINAL FLOW l/s	NUMBER OF SHUTTERS					I cm
	10 l/s	20 l/s	30 l/s	60 l/s	90 l/s	
30	1	1				16
60	1	1	1			32
90	1	1	2			48
120	1	1	1	1		63
150	1	1	2	1		79
180	1	1	1	2		94
210	1	1	1	1	1	109
240	1	1	1	3		125
300	1	1	1	1	2	155
360	1	1	1	2	2	186
420	1	1	1	3	2	217
480	1	1	1	1	4	247

Types DL₁ and DL₂

The individual units are less than 3.1 m wide. The maximum discharge of a unit is 1500 l/s. A concrete filling with a minimum thickness of 20 cm is required between two units. This filling must be taken into account in determining the total width.

NOMINAL FLOW l/s	NUMBER OF SHUTTERS				I cm
	50 l/s	100 l/s	200 l/s	400 l/s	
500	2	2	1		104
550	1	1	2		113
600	2	1	2		124
650	1	2	2		134
700	2	2	2	1	145
750	1	1	1	1	153
800	2	1	1	1	164
850	1	2	1	1	174
900	2	2	1	1	185
950	1	1	2	1	194
1000	2	1	2	1	205
1050	1	2	2	1	215
1100	2	2	2	1	226
1150	1	1	1	2	234
1200	2	1	1	2	245
1250	1	2	1	2	255
1300	2	2	1	2	266
1350	1	1	2	2	275
1400	2	1	2	2	286
1450	1	2	2	2	296
1500	2	2	2	2	307

Above 1500 l/s combine the above with one or more additional units in the following list.

NOMINAL FLOW l/s	NUMBER OF SHUTTERS 400 l/s	I cm
400	1	80
800	2	161
1200	3	242
	1	
	1	
	4	

Type DC₁ and DC₂

The individual units are less than 3.1 m wide. The maximum discharge of a unit is 3000 l/s. A concrete filling with a minimum thickness of 30 cm is required between two units. This filling must be taken into account in determining the total width.

NOMINAL FLOW l/s	NUMBER OF SHUTTERS					I cm
	100 l/s	200 l/s	400 l/s	600 l/s	1000 l/s	
1000	2	2	1			105
1100	1	1	2			114
1200	2	1	2			125
1300	1	1	1	1		134
1400	2	1	1	1		145
1500	1	2	1	1		155
1600	2	2	1	1		166
1700	1	1	2	1		175
1800	2	1	2	1		186
1900	1	1	1	2		195
2000	2	1	1	2		206
2100	1	2		1	1	215
2200	2	1	2		1	226
2300	1	1	1	1	1	235
2400	2	1	1	1	1	246
2500	1	2	1	1	1	256
2600	2	2	1	1	1	268
2700	1	1	2	1	1	276
2800	2	1	2	1	1	288
2900	1	1	1	2	1	296
3000	2	1	1	2	1	308

Above 3000 l/s combine the above with one or more additional units in the following list.

NOMINAL FLOW l/s	NUMBER OF SHUTTERS 1000 l/s	I cm
1000	1	100
2000	2	202
3000	3	303
	1	
	1	
	4	

DISTRIBUTOR SELECTION

Flow capacity and the type of longitudinal section (i.e. DX, DXX, DL or DC) are the main considerations in choosing equipment for a particular application. The type of section determines the width of the installation, the flow staggering, the permissible head loss, and the permissible upstream level range, depending on whether single or double baffle equipment is used, as indicated by Figure 1 or 2.

As shown in the tables on previous page, the flow ranges obtainable from the various series are as follows:

- Series DX: 30 to 150 l/s adjustable in steps of 5 l/s.
- Series DXX: 30 to 480 l/s adjustable in steps of 10 l/s.
- Series DL: 500 to 1500 l/s adjustable in steps of 50 l/s.
- Series DC: 1000 to 3000 l/s adjustable in steps of 100 l/s.

Additional DL and DC units allow to cope with higher capacities. As an example, fig. 6 shows the layout of a DL₁-2250 battery consisting of a standard 1450 l/s unit and an additional 800 l/s unit.

It follows from the above that Series DX and DXX distributors are generally more suitable for individual offtakes, while the larger Series DL and DC equipment is primarily intended for major offtakes.

Note: As a rule, it is not advisable to combine distributor units of different sizes (e.g. DXX and DC) in order for instance to adjust more accurately a large discharge, since the accuracy of the whole installation depends on the distributor of the higher series.

Figure 6

Typical layout of a DL₁-2250 battery of distributors.
Dimension in inches.

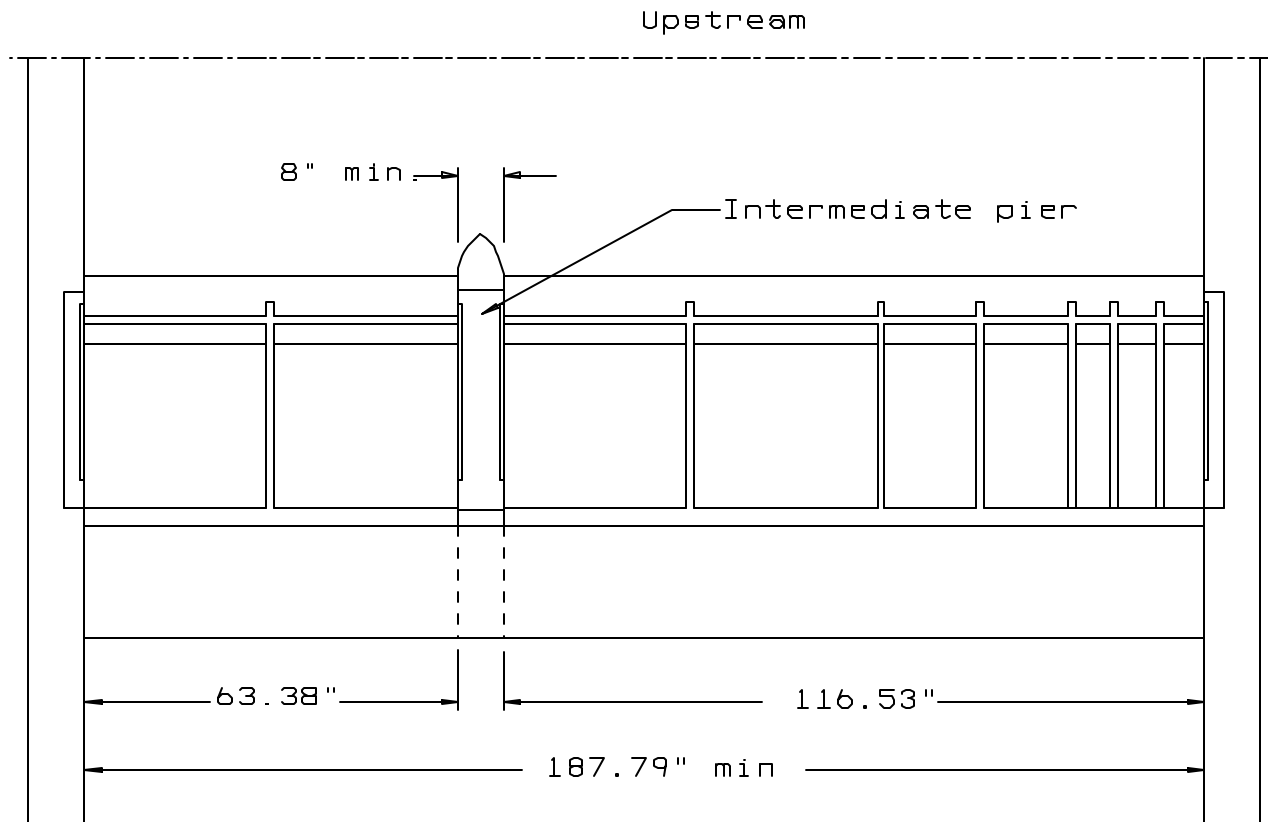

Note: We recommend to shape the upstream side of the intermediate piers like an ogive, with a radius of twice the pier thickness.

HEAD LOSS AND PERMISSIBLE LEVEL VARIATIONS FOR THE VARIOUS TYPES

Important Note:

The advantage of this equipment over turnouts fitted with submerged gates or streamlined weirs is evident from the permissible level range head loss

ratios the values of which are as follows:

- Single baffle distributor: 0.99 for $Q \pm 5\%$
- Single baffle distributor: 1.38 for $Q \pm 10\%$
- Double baffle distributor: 2.85 for $Q \pm 5\%$
- Double baffle distributor: 3.48 for $Q \pm 10\%$

In the same conditions, the values of this ratio for gates and faired sill offtakes operating under the same conditions are 0.22 and 0.49 for submerged gates and 0.17 and 0.35 for weirs.

HEIGHT SETTING

The curves on pages 64 and 65 show the relationship between flow and upstream level variations for both single and double baffle distributors.

By referring to these curves, the distributor can be set at its best operating height; in other words the height setting of the nominal level can be determined according to the water level variations just upstream of the turnout.

Example: Required: A 200 l/s distributor is to be installed at a point in a canal where the levels vary from 57.80 to 58.08 m.

Suitable distributor: A DC₁ distributor is suitable for these level variations, its width (about 2 meters) and head loss (24 cm at minimum upstream level) both being considered acceptable. According to the curve on page 59, and considering the appropriate above-sill height scale for this series of distributor, the required level range of 28 cm can be covered by setting the nominal distributor water level 10 cm below the maximum upstream level (i.e. at 57.98 m) in order to obtain the minimum flow variations.

The height setting of the distributor is thus fully defined, and a suitable structure should then be selected from the data on page 66 "Masonry Structure".

Heights in centimeters											
TYPE	Flow per unit sill width	H min. Q - 10%	H min. Q - 5%	H nom. Q	H max. Q + 5%	H max. Q + 10%	d H Q ± 10%	d H Q ± 5%	J min. for H nom.	J min. for H min.	P min. *
DX1	10 l/s/dm	13	13.5	17	18.5	20	7	5	6.5	5	16
DXX1	20 l/s/dm	20	21.5	27	29.5	31	11	8	10.6	8	25
DL1	50 l/s/dm	37	39.5	50	54.5	58	21	15	19	15	47
DC1	100 l/s/dm	59	62.5	79	86	92	33	23.5	30	24	75
DCC1	200 l/s/dm	94	100	126	137	146	52	37	48	38	118
DX2	10 l/s/dm	13	13.5	17.5	28	31	18	14.5	6.5	5	17
DXX2	20 l/s/dm	20	21	28	44	48	28	23	11	8	26
DL2	50 l/s/dm	37	39	51	82	89	52	43	20	15	49
DC2	100 l/s/dm	59	62	81	130	142	83	68	31	24	77
DCC2	200 l/s/dm	94	99	129	206	225	131	107	50	38	122

(*) P is the height of the sill above the upstream floor level (P = a - H nom.)

ASSOCIATION WITH AN AUTOMATIC GATE

Where the natural variations in level exceed those allowed by the distributor, they can be reduced to within the permissible range either by an automatic constant upstream level gate installed downstream of the diversion works or by a constant downstream level gate installed upstream or at the head of the diversion works. The height setting of the distributor, then normally of the single baffle type, must be determined according to the a.m. rules; however, for stability reasons, where the distributor is installed in series with the gate, its height setting must be chosen so that the controlled level keeps above the height of the point T with a vertical tangent on the characteristic curve. As the case may be, the level decrement due to the gate itself, as well as the variations in the water line due to the head losses between the point where the level is controlled and the distributor, are to be taken into account.

Characteristic line of single baffle distributors

Above-sill height in centimeters

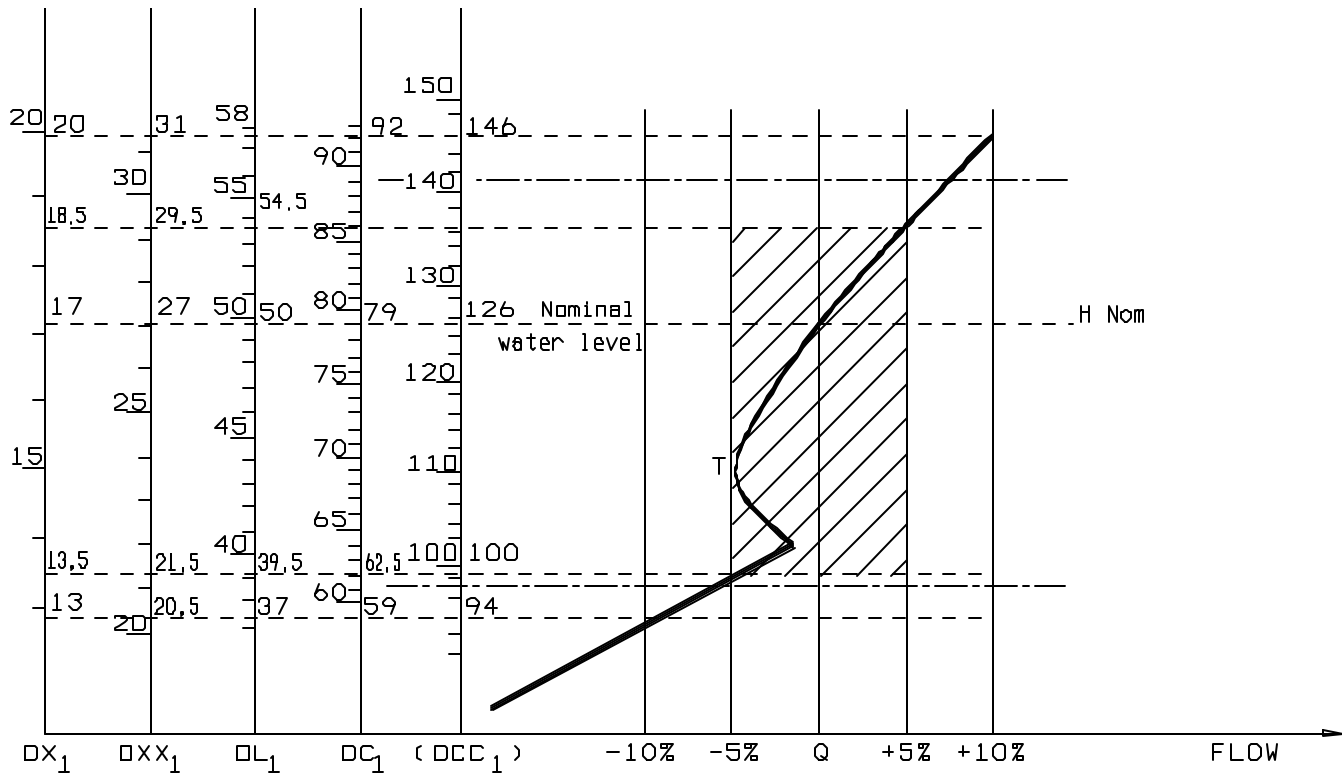

Note: Some changes in the flow may result from the location of the unit in the works or from the relative positions of the shutters closed and open. Therefore, the flow/height characteristic curve must not be considered as a well defined line but only as a middle-line of possible operating points, however, all situated within the normal tolerance zone of the distributor.

Characteristic line of double baffle distributors

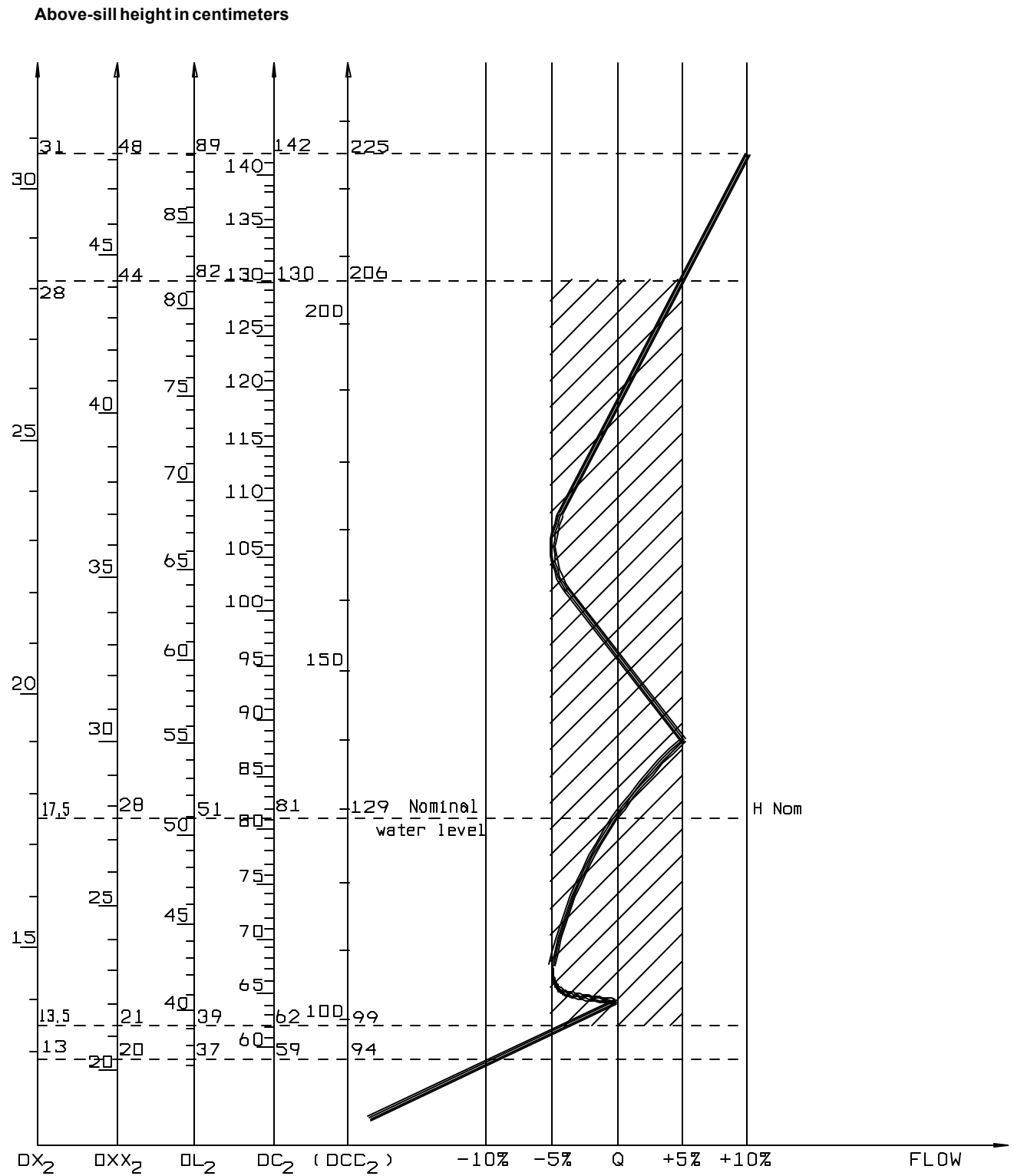

Note: If a single baffle distributor seems to meet the requirements of a given level variation, the use of a double baffle distributor in its place would not entail a greater precision.

MASONRY STRUCTURE

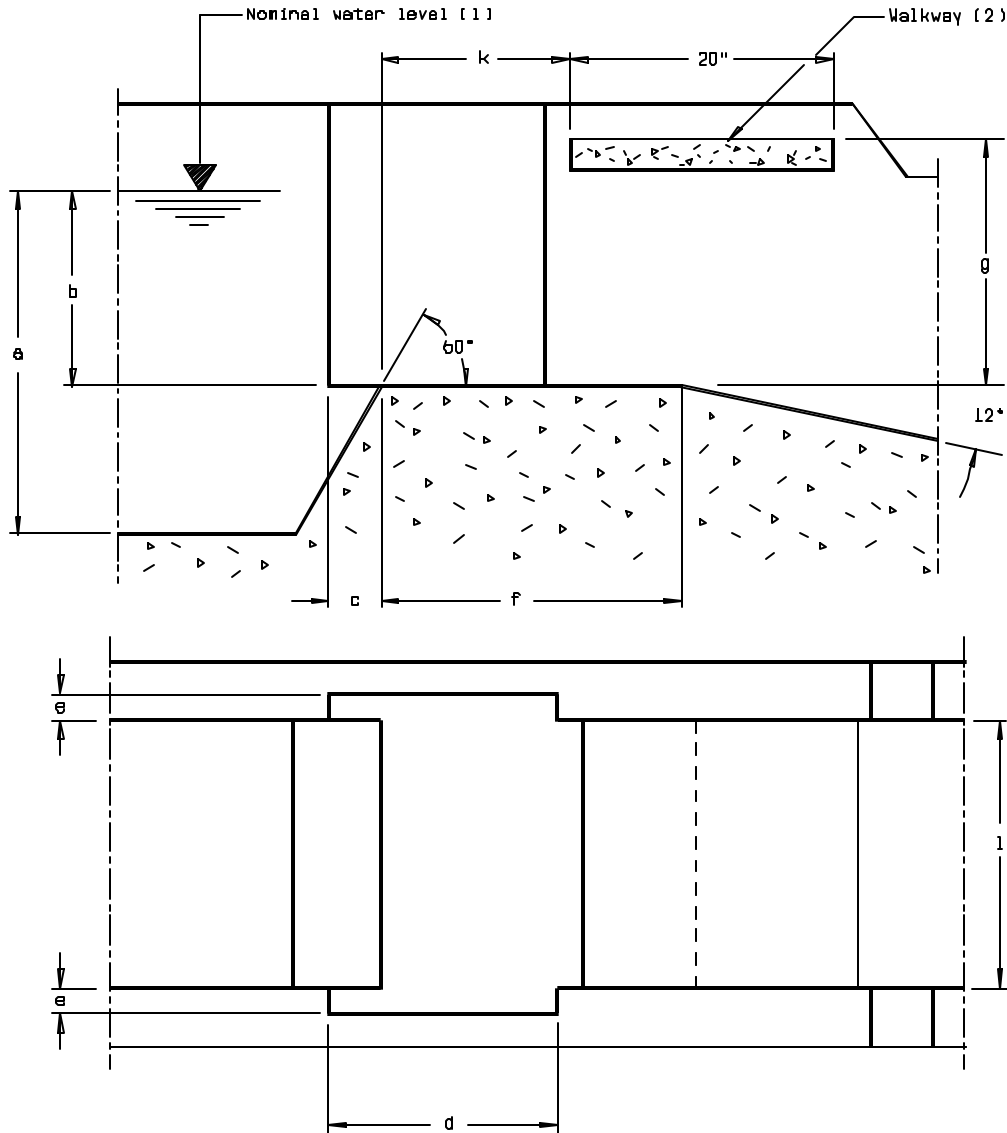

DIMENSIONS IN CENTIMETERS

DISTRIBUTOR	a min.	b	c	d	e	f	g	k	l
DX1	33	25	9	34	5	45	35	25	See page 61 Standard Units
DXX1	52	37	10	46	5	57	47	36	
DL1	97	68	16	94	10	103	68	85	
DC1	154	105	25	140	15	146			
DX2	35	26	3	36	5	48	49	40	
DXX2	54	40	4	54	5	68	70	60	
DL2	100	75	20	115	10	135	105	100	
DC2	158	120	25	170	15	210			

A 50 cm wide walkway is required downstream of the distributor for shutter setting purposes if "l" is greater than 1 meter. Type DC distributors are supplied with a metal walkway integral with the unit.

PRACTICAL RECOMMENDATIONS

Controllable constant-flow water turnouts are either used downstream of reservoirs or basins, or on river dams at the head of main canals under upstream control or at the head of secondaries or tertiaries branched to supply canals, or mains of restricted capacity.

RESERVOIRS, DAMS, STORAGE BASINS

The type of equipment used on a water turnout depends on the range of upstream level variations it has to deal with. It may either consist of a simple battery of single or double-baffle distributors or, if required by the water level variations in the reservoir, of an automatic constant downstream level gate (e.g. Waterman Type "A", "B" or "C", or cylindrical valve) controlling an intermediate water level upstream of a battery of distributors.

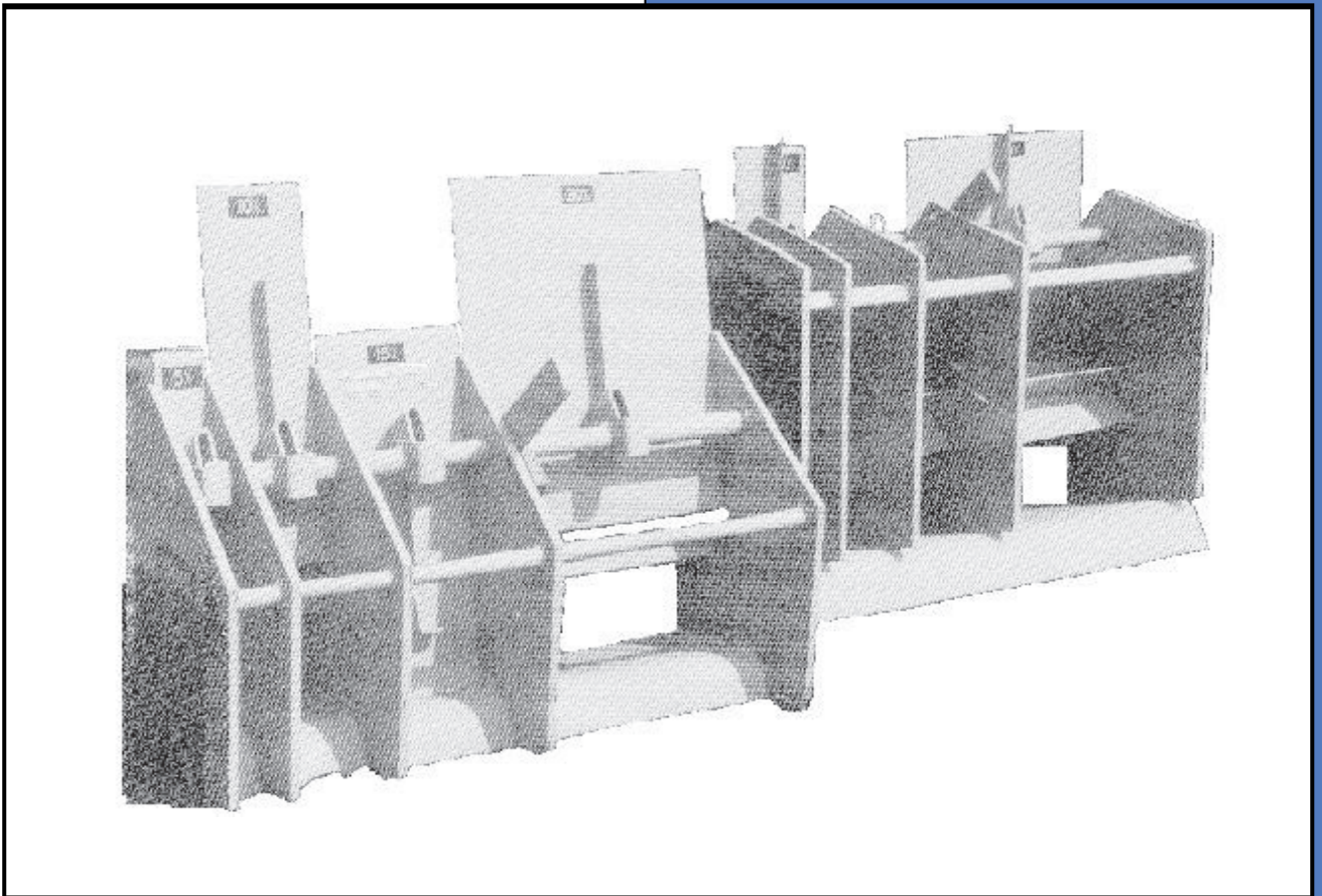

Single baffle DX₁-60 distributor and double baffle DX₂-60 distributor on stock-yard.

TURNOUTS ON CANALS CONTROLLED FROM UPSTREAM

Canals of this type are subdivided into a series of reaches by cross regulators such as Waterman Type "C" constant upstream level gates.

Their water surfaces vary from a horizontal surface at a definite level at zero flow, to a sloping surface above this line at maximum flow (see Figure 7).

Let D_1 and D_2 be the level ranges covered by a single and double-baffle distributor respectively. Zones bV_n and "a" "b" thus correspond respectively to parts of the canal in which a turnout consisting of a simple distributor of the appropriate type can be installed.

The possible alternative for zone V_{n-1} to "a" are then as follows:

- 1- An additional regulator (e.g. a Waterman Type "C" gate) on the supply canal immediately downstream of

the turnout, the latter being fitted with a distributor (see Figure 8).

- 2- A constant downstream level gate (e.g. a Waterman Type "A" or "B" gate) on the branch canal, followed by a distributor (see Figure 9).

The choice between these alternatives results from a cost comparison between the automatic gates considered. The Waterman Type "C" gate should be dimensioned for the primary canal flow and produce low head losses, whereas the Waterman Type "A" or "B" gate should be matched to the branch canal flow. The first alternative is particularly attractive if other turnout farther upstream are likely to be affected by the Waterman Type "C" gate; this alternative also ensures a higher water level downstream of the turnout.

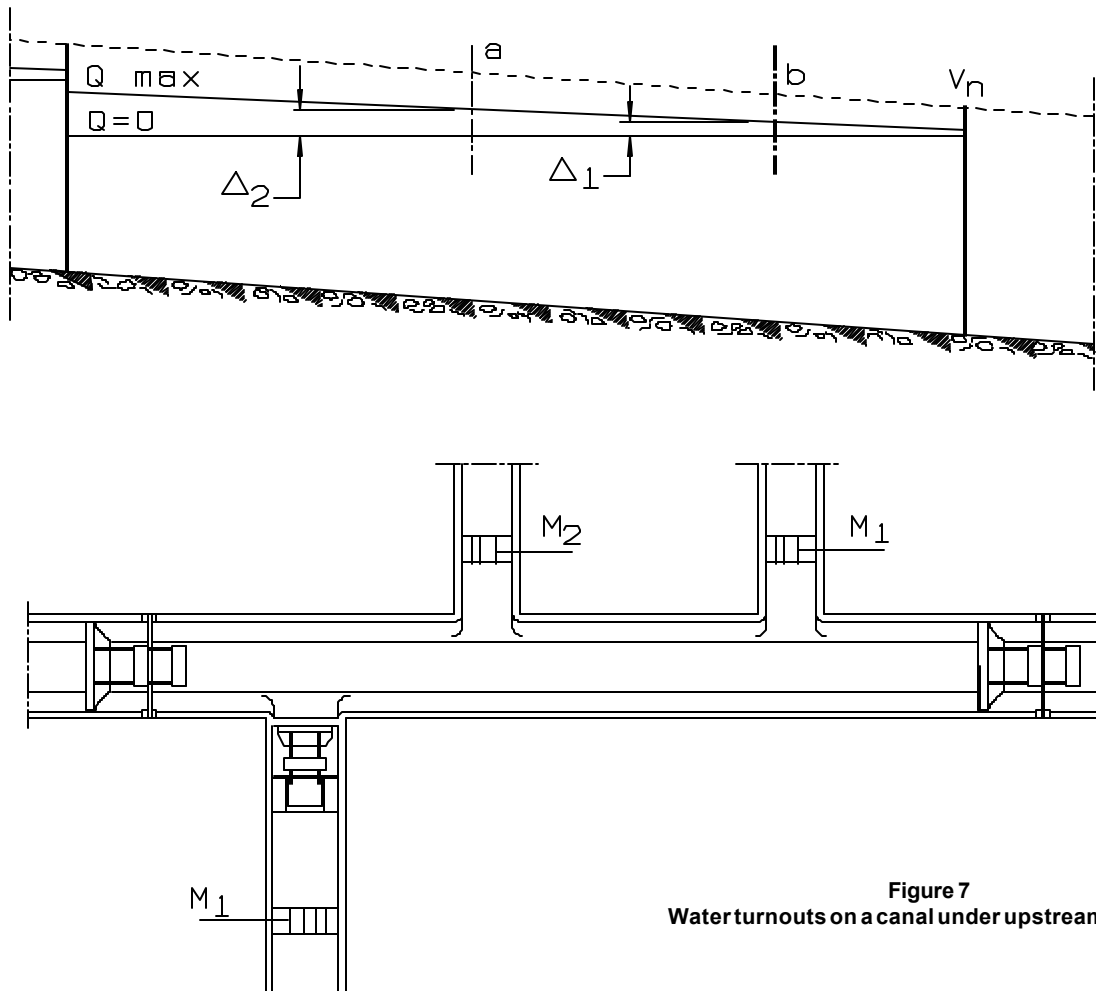

Figure 7
Water turnouts on a canal under upstream control.

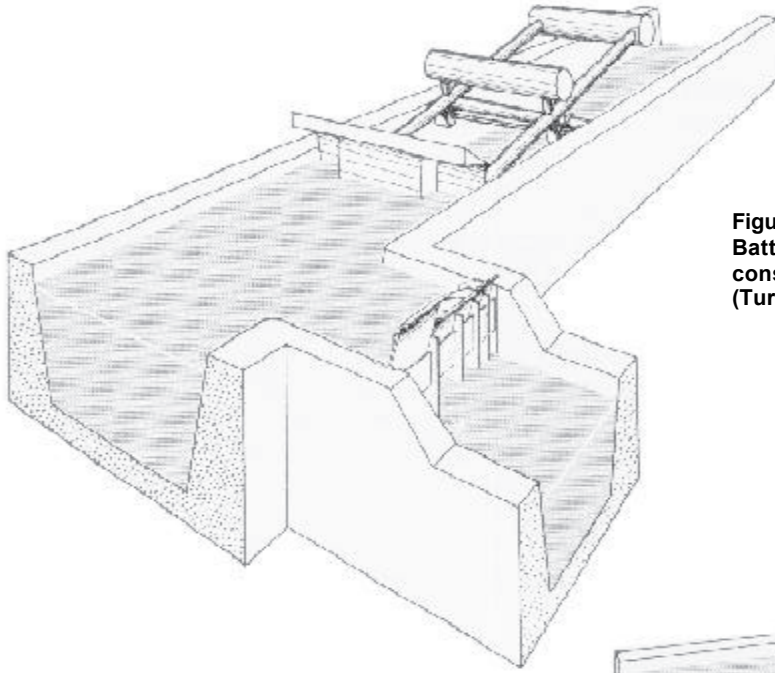

Figure 8
Battery of distributors in conjunction with a constant upstream level gate in the main canal.
(Turnout on upstream-controlled canal).

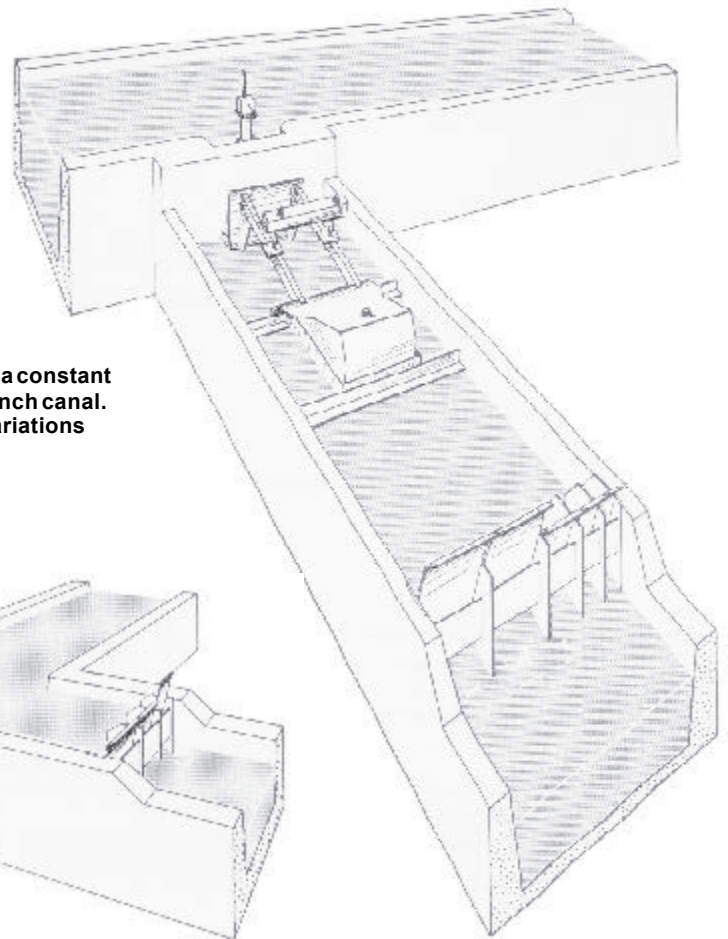

Figure 9
Battery of distributors in conjunction with a constant downstream level gate at the head of a branch canal.
(Turnout on canal or reservoir with level variations exceeding the distributor level range.)

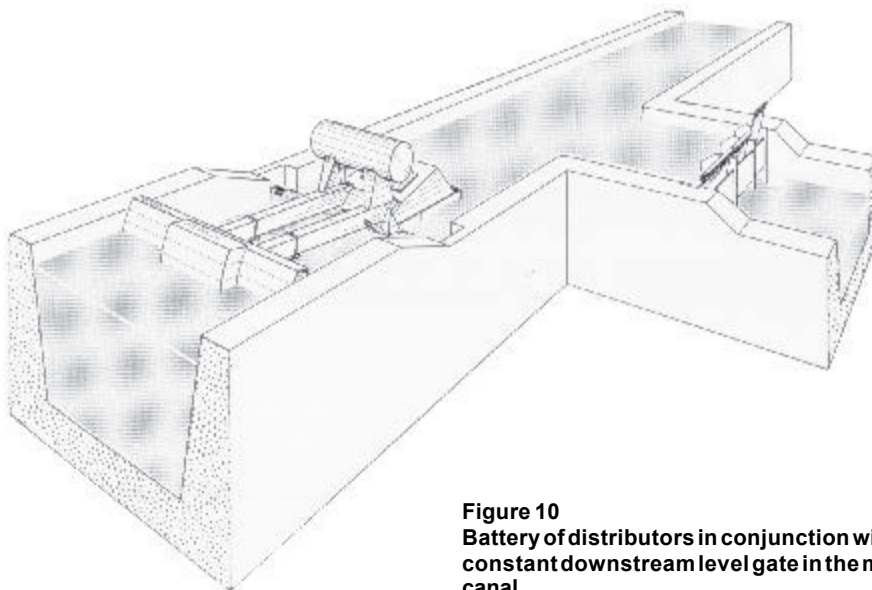

Figure 10
Battery of distributors in conjunction with a constant downstream level gate in the main canal.
(Turnout on downstream-controlled canal).

TURNOUTS ON CANALS CONTROLLED FROM DOWNSTREAM

These canals are subdivided into reaches by automatic constant downstream level gates (such as Waterman Type "A" and "B" gates).

In this case, the water surface varies from a sloping surface at maximum flow to a horizontal line above it at zero flow (see Figure 11).

Zones V_n "a" and "a" "b" are parts of the canal in which the lateral turnouts can each be fitted with a single or double-baffle distributor.

The possible alternatives for zone b V_{n-1} are as follows:

- 1- An additional control gate (e.g. Waterman Type "A" gate) immediately upstream of the turnout, which should be provided with a distributor (see Figure 10).
- 2- A gate of the Waterman Type "A" or "B" on the branch canal followed by a distributor (see Figure 9).

As in the previous case, the choice depends on economic consideration, alternative 1 being the more attractive if other turnouts farther downstream are likely to be affected by the additional gate.

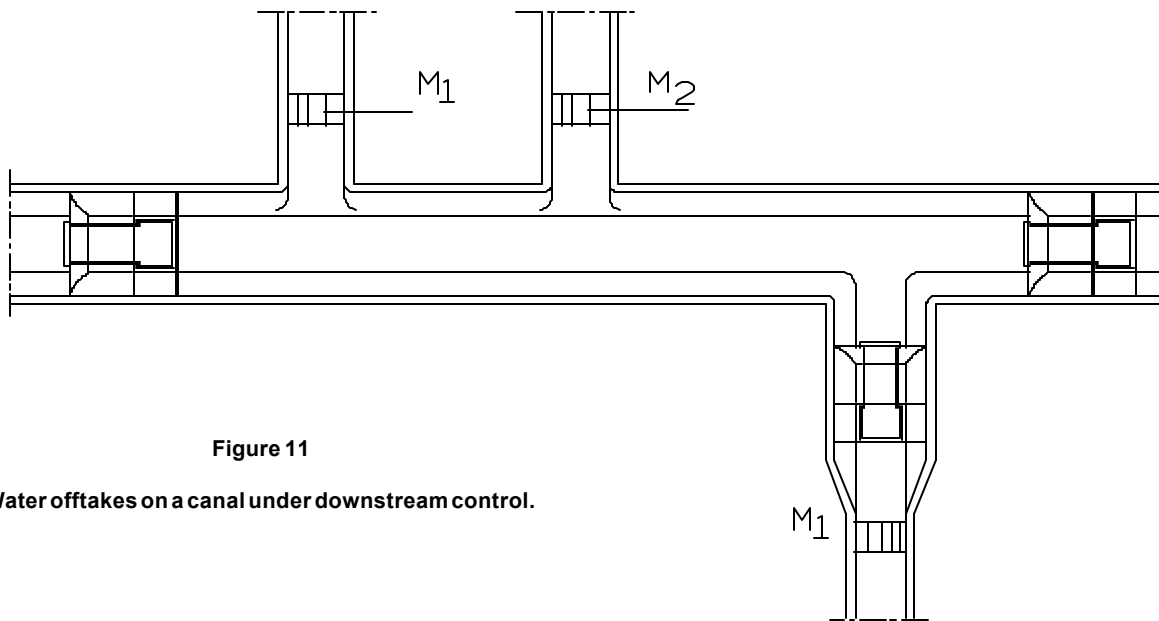
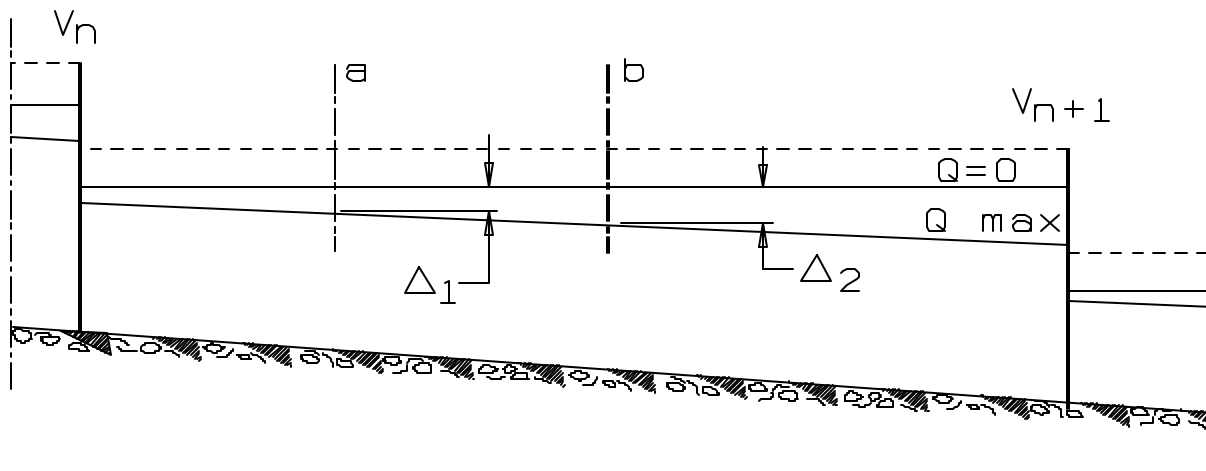

Figure 11

Water offtakes on a canal under downstream control.

CONCLUSION

Waterman distributors, by means of an artful application of simple hydraulic principles offer considerable advantages in flow control.

Their simple though improved design has resulted in a hard-wearing form of equipment, which is well able to cope with the very severe conditions under which it sometimes has to operate.

Waterman distributors are therefore a really effective means of making the most rational use of available water supplies and running canal systems on the most economical basis. They also provide an attractive and original answer to the problem of flow control equipment for water turnouts and other free-structure works.



Battery of DCC₂ distributors. Max. flow 114 m³/s.