

# F-55 HEAVY DUTY DRAINAGE GATE

- CAST IRON CONSTRUCTION
- AUTOMATIC OPERATION
- 55 FOOT SEATING HEAD MAXIMUM

Model F-55 Gates are furnished with a flangeback frame. Frame, cover (flap) and adjustable hinge blocks are cast iron. Standard hinge links are flame cut steel or ductile iron. Assembly bolts, hinge pins and keepers are type 304 stainless steel. Hinge bushings are bronze.

Gate features a minimum of 2½° seat incline to assure positive closing. Finished seating faces are machined to a flat plane within .002 T.I.R.

Optional dovetail bronze seat faces, stainless steel seat faces, and a dovetail neoprene seat in either the cover or frame are available. **A leaf spring bumper with rubber cushion block can be furnished when the gate is used on pump discharge lines.**

#### Other Optional Items Include:

- Ni-Resist frame, cover and hinge block
- Type 304 or 316 stainless steel links
- Manganese bronze hinge links
- Non-metallic hinge bushings
- Type 316 stainless steel assembly hardware
- 125 lb. ANSI standard drilling
- Permalube Bronze Bushings
- Special paint coatings
- Total Galvanizing
- Lube Fittings



PARTS LIST		
No.	Name	Qty.
1	FRAME	1
2	COVER	1
3	PIVOT LUG	2
4	HINGE LINK	2
5	HINGE STUD	4
6	HINGE NUT	12
7	HINGE PIN	4
8	HINGE BUSHING	4
9	WASHER	8
10	HINGE PIN	4
11	SET SCREW	2
12	JAM NUT	2
13	BUMPER BOLT	2
14	NUT	2
15	BUMPER	1
16	SPRING ELEMENT	3
17	BOLT	2

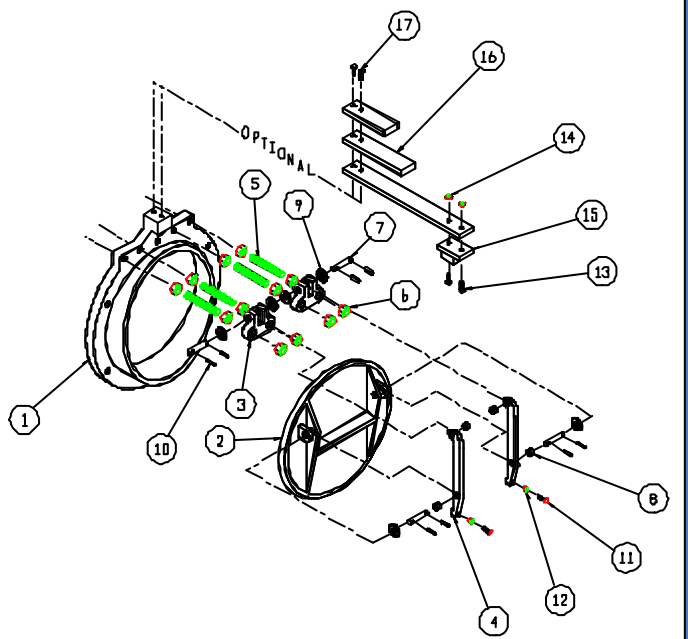

# F-55 AUTOMATIC DRAINAGE GATE

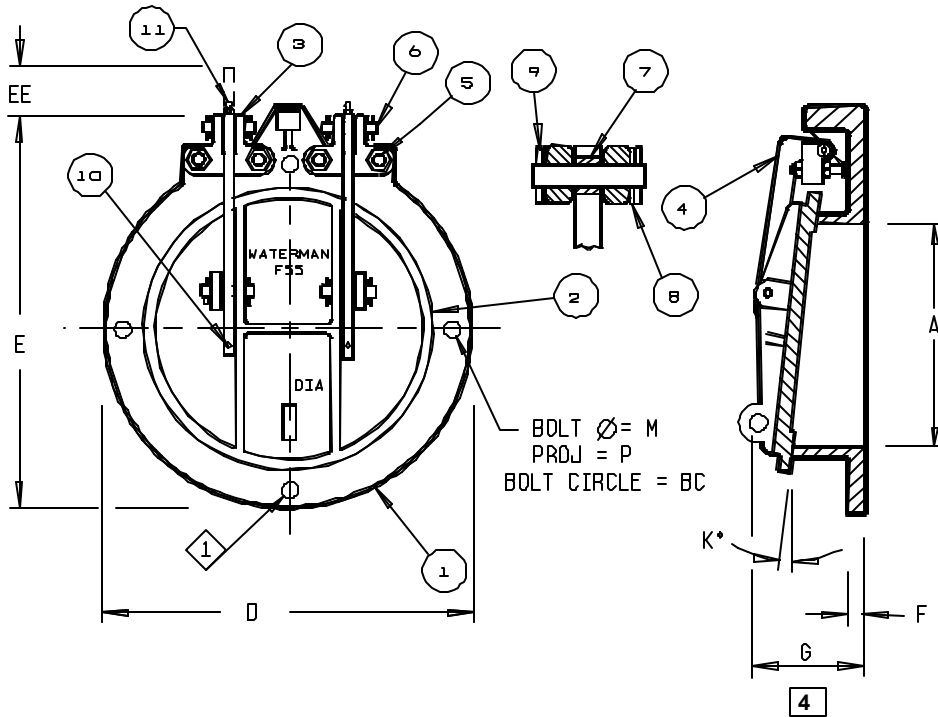

PARTS LIST	
No.	Name
1	FRAME
2	COVER
3	PIVOT LUG
4	HINGE LINK
5	HINGE STUDS & NUTS
6	HINGE PIN
7	HINGE BUSHING
8	WASHERS
9	SPRING PIN
10	SET SCREW
11	LUBE FITTING (optional)

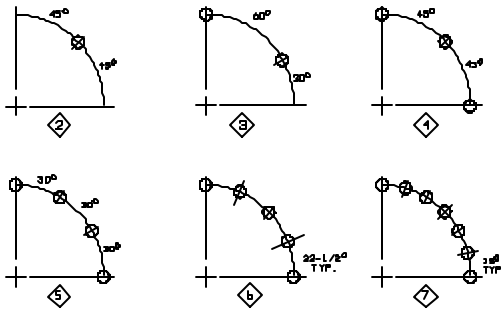
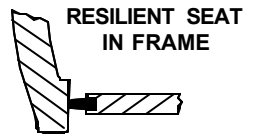
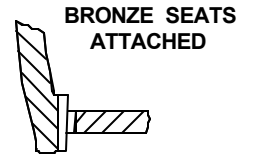

- 25 Lb. & 125 Lb. Std. Drilling available on request for all gates except 15" & 21".
- For use with seating heads up to 55 feet. 108" gate suitable for use to 30Ft. only.
- "F" Dimensions are machined dimensions, may be 1/4" thicker.
- If grout pad mounting is used, add grout thickness to dimension.

GATE DIMENSIONS IN INCHES

GATE SIZE A	4	6	8	10	12	14	15	16	18	20	21	24	30	36	42	48	54	60	66	72	84	96	108
BC	7½	9½	1¾	14¼	17	18¾	20	21¼	22¾	25	25	29½	36	42¾	49¾	56	62¾	69¼	76	82½	95½	108½	119½
D	9	11	13½	16	19	21	22½	23½	25	27½	27½	32	38¾	46	53	59¾	66½	73	80	86½	99¾	113¼	124
E	9¾	12	14½	16	19	22	25	24	28½	28	30	35	40½	46½	54¾	66	72	75	85¼	92¼	105½	119	130
EE	1⅞	2	2⅞	2⅞	3	3⅞	3⅞	3	3⅞	3⅞	2⅞	3	3½	3½	4⅞	4⅞	6	6⅞	7	10	10	10	10
F [3]	⅝	¾	¾	13/16	7/8	7/8	7/8	7/8	1	1	1	1	1⅜	1⅜	1½	1½	1¾	1¾	2¼	2¼	2¼	2¼	2½
G	3⅞	2½	2¾	3	3½	6	6½	6½	7	7	7½	8	8	9	8½	10	10	10¼	14	14½	17	21	21
K	5	5	5	5	5	5	5	5	5	5	5	2½	2½	2½	2½	2½	2½	2½	2½	2½	2½	2½	2½
M	⅝	⅝	⅝	⅝	¾	¾	¾	¾	¾	¾	¾	¾	7/8	7/8	1	1	1	1⅞	1⅞	1⅞	1¼	1¼	1¼
P	1½	1½	1½	1½	1½	1½	1½	1½	1½	1¾	1¾	1¾	2¼	2¼	2¼	2⅞	2¾	3	3	3½	4	4½	4½
NO. OF BOLTS	4	4	4	6	6	6	6	6	6	8	8	8	8	8	12	12	12	12	12	16	16	16	24
◇	2	1	1	3	3	3	3	3	3	4	4	4	4	4	5	5	5	5	5	6	6	6	7

NOTE: FOR PRELIMINARY DESIGN PURPOSES ONLY  
DO NOT USE FOR INSTALLATION  
UNLESS PART OF CERTIFIED & APPROVED SUBMITTAL

**TYPICAL SPECIFICATIONS**  
**F-55 HEAVY DUTY AUTOMATIC DRAINAGE (FLAP) (TIDE) GATES**

**General**

The drainage gate shall be designed to allow free outflow and prevent backflow for maximum seating heads up to 55 feet. Gates shall be Waterman Model F-55 or equal.

**Construction**

The frame shall be cast iron of flatback design with machined seating surface inclined from vertical, at minimum of 2½°, to assure positive closure. For flatback gates mounted to thimbles or flanges, the gate flange shall be machined and drilled to match.

The cover shall be cast iron, cast in one piece, with reinforcing ribs, designed to withstand the seating head specified. An integral cast on lifting eye shall be provided for manual operation.

Seating surfaces for frame and cover shall be:

a) Machined iron

or

b) Bronze seats impacted into dovetail grooves on frame and cover

or

c) Bronze seats impacted into dovetail grooves within frame with neoprene seat bonded into dovetail groove in cover to cushion cover on closing

or

d) Bronze seats impacted into dovetail grooves in cover with neoprene seat bonded into groove in frame.

All machined seats shall have a minimum 63 microinch finish.

The gate shall be provided with adjustable, double pivoted hinge links so designed to permit complete seating, full opening, and with stops or other arrangements to prevent cover from rotating sufficiently to become wedged in the open position. Pivot lugs mounted to frame shall be adjustable to allow adjustment of hinge links without having to remove cover from gate. The hinge links (arms) shall be bronze-bushed galvanized structural steel. Optional hinge links of ductile iron, stainless steel (both bronze-bushed), and manganese bronze may be specified.

All assembly hardware and hinge pins shall be Type 18-8 stainless steel.

**Finish**

All cast iron shall be painted with manufacturer's standard shopcoat paint (or special paint). Structural steel hinge links shall be galvanized. All bronze and stainless steel parts do not require further finish.

**Materials**

Frame and Cover - Cast Iron per ASTM A-126, Class B.

Pivot Lug - Ductile Iron per ASTM A-536, Gr. 65-45-12.

Hinge Link - Structural Steel per ASTM A-36, galvanized per ASTM A-123.

Bronze Bushings and Washers - Commercial Bronze.

Assembly Hardware and Hinge Pins - 18-8 Stainless Steel (Type 304).

**Optional Materials**

Naval Bronze Seats - ASTM B-21, Alloy 482.

Low-Zinc Bronze Seats - ASTM B-139.

Neoprene Seats - ASTM D-2000 BC610/625.

Ductile Iron Hinge Link - ASTM A536, Gr. 65-45-12.

Manganese Bronze Hinge Link - ASTM 584, Alloy 865.

Stainless Steel Hinge Link - ASTM A-276, Type 304

Bronze Hardware - ASTM B-98.

Ni-resist Cast Iron Frame and Cover - ASTM A-436, Type 2 or 2B.