

F-40 HEAVY DUTY DRAINAGE GATE

- CAST IRON CONSTRUCTION
- AUTOMATIC OPERATION
- 40 FOOT SEATING HEAD MAXIMUM
- SQUARE AND RECTANGULAR OPENING
- STAINLESS STEEL STUDS, NUTS AND PINS
- FLATBACK
- ADJUSTABLE LINKAGE
- CAST IRON OR BRONZE SEATS
- GALVANIZED STEEL LINKS
- BRONZE HINGE BUSHINGS
- MINIMUM 2½° SEAT

The Waterman Model F-40 Cast Iron Automatic Drainage Gate has a cast iron frame and cover (flap) with machined finished seating surfaces. A minimum 2½° seating angle and double pivoted links assure positive seating.

Hinge brackets, which can easily be field adjusted, allow the gate to be set for a very sensitive opening under low unseating pressure. Out-flow at practically full conduit capacity can be obtained.

Standard features include bronze hinge bushing, stainless steel hinge pins, studs and nuts with brass retainer washers and stainless steel spring pins. Links on all gates are flame cut from steel plate, then galvanized.

A lifting eye is cast as a part of the cover for hand operation.

Optional features available include bronze or stainless steel seats, monel or brass hinge pins, studs and nuts; graphite impregnated bronze bushings and lubrication fittings - or any combination thereof.

Standard shopcoat paint is an asphaltic base dipping enamel. All special coatings are available and include Epoxy and Coal Tar Paints or total galvanizing per ASTM A-123.

Anchor bolts are not included and should be ordered separately. Anchor bolts of galvanized steel, stainless steel, brass or monel are available as well as stainless steel machine bolts and tap-in expansion anchors.

Optional:

- Monel Studs, Nuts and Pins
- Coal Tar, Epoxy, and other Special Coatings including Total Galvanizing
- Stainless Steel, Ductile Iron or Manganese Bronze Hinge Links



FLATBACK F-40f

PARTS LIST	
No.	Name
1	FRAME (FLATBACK)
2	HINGE PINS
3	PIVOT LUG
4	STUDS & STUD NUTS
5	COVER (FLAP)
6	HINGE LINK
7	WASHER
8	RETAINING SPRING PIN
9	BUSHING
10	SET SCREW

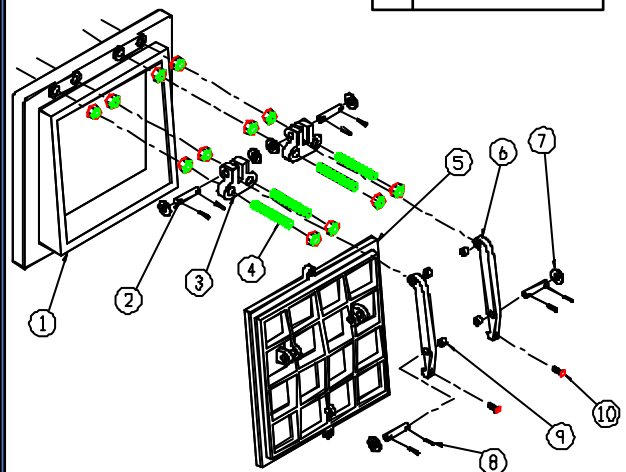

40-f DRAINAGE GATE

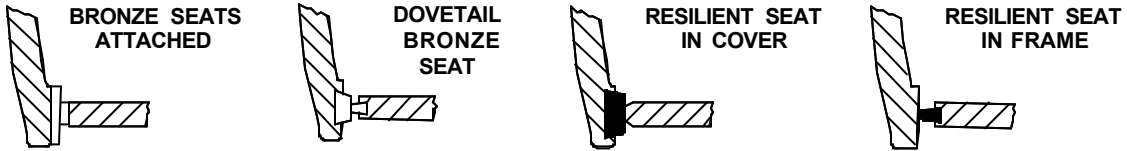
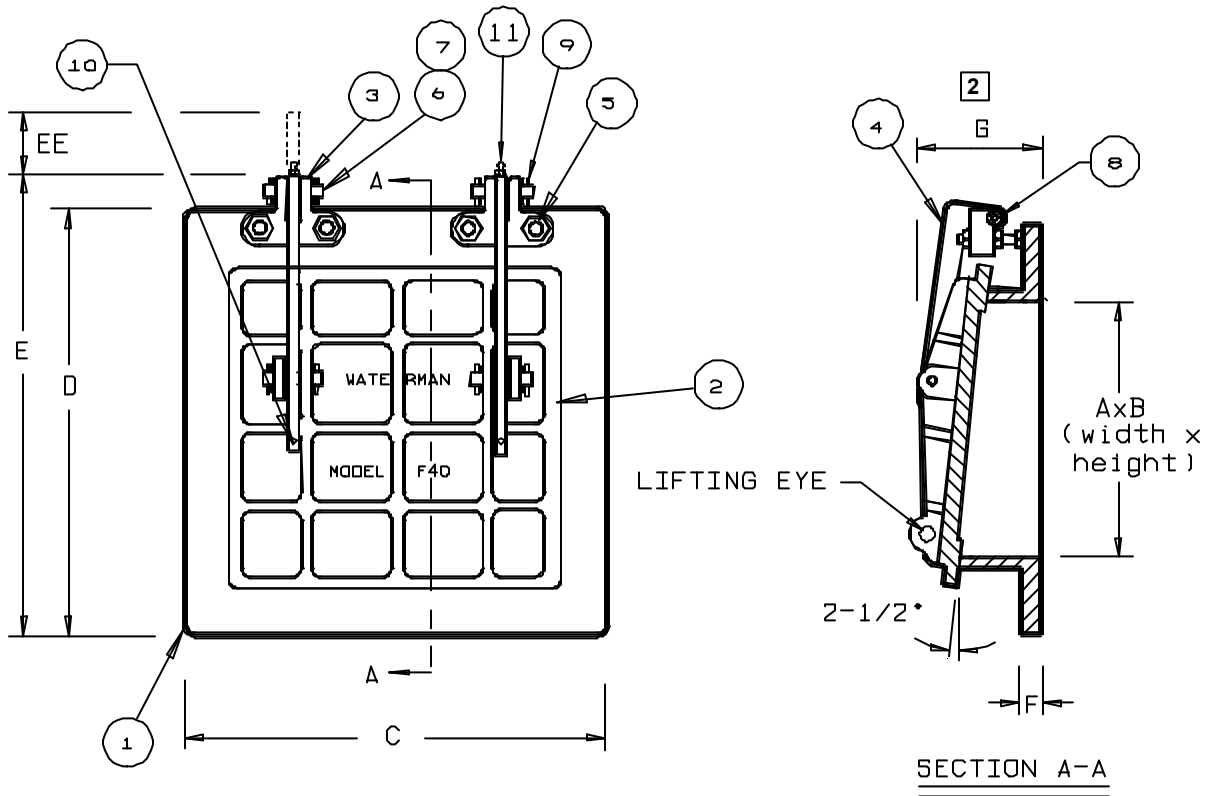

1. For use with seating heads up to 40 feet.
2. If grout pad mounting is used, add grout thickness to dimensions.

PARTS LIST	
No.	Name
1	FRAME
2	COVER
3	PIVOT LUG
4	HINGE LINK
5	HINGE STUDS & NUTS
6	HINGE PIN
7	HINGE BUSHING
8	WASHERS
9	SPRING PIN
10	SET SCREW
11	LUBE FITTING (non-corrosive)

GATE DIMENSIONS IN INCHES

A X B	C	D	E	EE	F	G
24 X 24	35	35	37	3½	1	8¼
30 X 30	38½	38½	40½	3½	1⅛	8
36 X 24	47	35	37	3½	1¼	10
36 X 36	45	45	47	3½	1½	12
42 X 42	53	53	55	4¼	1½	13
48 X 36	59	47	49	3½	1½	12
48 X 48	58	58	62	5	1½	10
54 X 36	65	47	49	3½	1½	11
54 X 54	65	65	69	6	1½	13
60 X 30	71	41	43	3½	1½	11
60 X 36	71	47	49	3½	1½	13
60 X 60	71	71	75	6	1½	13
72 X 72	84	84	88	10	1¾	15
84 X 84	96	96	100	10	1¾	15
96 X 96	108	108	112	10	2	20
96 X 120	112	136	142	11	2	20
108 X 108	124	124	130	11	2	20
120 X 120	136	136	142	11	2	20

NOTE: FOR PRELIMINARY DESIGN PURPOSES ONLY
DO NOT USE FOR INSTALLATION
UNLESS PART OF CERTIFIED & APPROVED SUBMITTAL

TYPICAL SPECIFICATIONS
F-40 HEAVY DUTY AUTOMATIC DRAINAGE (FLAP) (TIDE) GATES

General

The flap gate shall be designed to allow free outflow and prevent backflow for maximum seating heads up to 40 feet. Gates shall be Waterman Model F-40 or equal.

Construction

The frame shall be cast iron of flatback design with machined seating surface inclined from vertical, at minimum of $2\frac{1}{2}^{\circ}$, to assure positive closure. For flatback gates mounted to thimbles, the gate flange shall be machined and drilled to match thimble.

The cover shall be cast iron, cast in one piece, with reinforcing ribs designed to withstand the seating head specified. An integral cast on lifting eye shall be provided.

Seating surfaces for frame and cover shall be:

- a) Machined iron
- or
- b) Bronze seats impacted into dovetail grooves on frame and cover
- or
- c) Bronze seats impacted into dovetail grooves within frame with neoprene seat bonded into dovetail groove in cover to cushion cover on closing.
- d) Bronze seats impacted into dovetail grooves in cover with neoprene seat bonded into groove in frame.

All machined seats shall have a minimum 63 microinch finish.

The gate shall be provided with an adjustable, double pivoted hinge linkage so designed to permit complete seating, full opening, and with stops or other arrangements to prevent cover from rotating sufficiently to become wedged in the open position. Pivot lugs mounted to frame shall be adjustable to allow adjustment of hinge links without having to remove cover from gate. The hinge links (arms) shall be bronze-bushed galvanized structural steel. Optional hinge links of ductile iron, stainless steel (both bronze-bushed), and manganese bronze may be specified. All assembly hardware and pivot pins shall be Type 18-8 stainless steel.

Finish

All cast iron shall be painted with manufacturer's standard shopcoat pain (or special paint). Structural steel hinge arms shall be galvanized. All bronze and stainless steel parts do not require further finish.

Materials

Frame and Cover - Cast Iron per ASTM A-126, Class B.

Pivot Lug - Ductile Iron per ASTM A-536, Gr. 65-45-12.

Hinge Link - Structural Steel per ASTM A-36, galvanized per ASTM A-123.

Bronze Bushings and Washers - Commercial Bronze.

Assembly Hardware and Pins - 18-8 Stainless Steel (Type 304).

Optional Materials

Naval Bronze Seats - ASTM B-21, Alloy 482.

Low-Zinc Bronze Seats - ASTM B-139.

Neoprene Seats - ASTM D-2000 BC610/625.

Ductile Iron Hinge Link - ASTM A536, Gr. 65-45-12.

Manganese Bronze Hinge Link - ASTM 584, Alloy 865.

Stainless Steel Hinge Link - ASTM A-276, Type 304.

Bronze Hardware - ASTM B-98.

Ni-resist Cast Iron Frame and Cover - ASTM A-436, Type 2 or 2B.