

SS-250-1 SERIES STAINLESS STEEL SLIDE GATE

- THE BEST OF TECHNOLOGY FOR STRENGTH AND LONGEVITY IN CORROSIVE ATMOSPHERES
- 304 OR 316 STAINLESS STEEL WITH UHMW PLASTIC SLIDING AND SEATING SURFACES
- MEETS LEAKAGE REQUIREMENTS OF AWWA C-561

ADVANTAGES:

Corrosion Resistant
Optimum Sealing Against Leakage
Rugged Heavy Duty Design

SS-250-1 Series Slide Gates are engineered for excellent sealing while providing maximum resistance to corrosion. Ultra High Molecular Weight Polyethylene (UHMW) sliding and seating surfaces, dissimilar from the gate slide material, provides low coefficient of friction while maintaining the superior resistance to corrosion. SS-250 Series gates may be specified with optional type 316L stainless steel for use in unusually corrosive environments such as hydrogen sulfides or salt water.

PERFORMANCE:

SS-250-1 Series Slide Gates can be custom designed for 5, 10, 15 or 20 feet of head, heavy duty gates available up to 50 feet of head (some limitations apply to larger sizes). SS-250-1 gates are available in normal aperture configurations or as weirs (downward opening). They may also be ordered as self-contained gates or with extension stems and separate operators.

Also available: A-250-1 Series Aluminum Slide Gates.



SS-251-1

SS-250-1 STAINLESS STEEL SLIDE GATE CONFIGURATIONS							
TYPE OF GATE	APERATURE		END OF CHANNEL			IN CHANNEL	
(OPENING)	STANDARD	DOWNWARD OPENING	UPWARD OPENING	DOWNWARD OPENING (WEIR)	NON-RESTRICTED FLOW (WEIR)	EMBEDDED GUIDE	WALL MTD. GUIDE
RIISING STEM MIN HEAD 1	251-2	252-1	253-1	254-1	255-1	256-1	257-1
MODIFIERS							
INCREASED HEAD CAPACITY							
10FT	261-1	262-1					
15FT	271-1	272-1					
20FT	281-1	282-1					
MACHINED FLANGE	251-1-F	252-1-F					
CIRCULAR FLANGE	251-1-CF	252-1-CF					
FULLY CONTAINED GATE IN SLIDE	251-1-L	252-1-L	253-1-L	254-1-L	255-1-L	256-1-L	257-1-L
SELF-CONTAINED GATE	251-1-Y	252-1-Y	253-1-Y	254-1-Y	255-1-Y	256-1-Y	257-1-Y
NRS COVER	251-1-N	252-1-N	253-1-N	254-1-N		256-1-N	257-1-N
SPECIAL OR MODIFIED APPLICATION	251-1-X	252-1-X	253-1-X	254-1-X	255-1-X	256-1-X	257-1-X

1 Minimum head is 5FT to center line for types 251-1 & 252-1 and 1ft above top of gate for type 253-1 thru 257-1

2 Model 258-1 is a gate with special modifications to incorporate two models in one gate.

TYPICAL SPECIFICATIONS FOR SS-250-1 SERIES FABRICATED SLIDE GATE

GENERAL

The gates shall be either self-contained with yoke and bench stand operators, or non-self-contained with separate stem guides and operator, in accordance with the requirements of these specifications. Specific configurations shall be as noted on the gate schedule or as shown on the plans.

FRAME AND GUIDES

The gate frame shall be a rigid unit composed of stainless steel guide rails with UHMW seats upstream and downstream. These shall form a tight seal between the frame and the slide (disc). This tight seal shall provide an allowable leakage rate of no more than 0.1 gallons per minute (GPM) per peripheral foot of perimeter opening for seating heads and 0.1 GPM per peripheral foot for unseating heads. Stainless Steel retainer bars, cross bars and head rails (for self-contained gate only) shall be provided. The clear opening shall be the same size as the waterway, unless otherwise specified. The guides will be of sufficient length to support two-thirds of the height of the slide when in the full open position.

SLIDE COVER (DISC)

The slide cover (disc) shall be stainless steel plate reinforced with structural shapes welded to the plate. The slide cover shall not deflect more than 1/720th of the span of the gate under the maximum head. The stem connection shall be either the clevis type, with structural members welded to the slide and a bolt to act as a pivot pin, or a threaded and bolted (or keyed) thrust nut supported in a welded nut pocket. The clevis or pocket and yoke of the gate shall be capable of taking, without damage, at least twice the rated thrust output of the operator at 40 pounds pull.

FLUSHBOTTOM CLOSURE

Gates shall be furnished with a flush seal arrangement. A resilient seal with a minimum width of exposed face of 3/4" shall be securely attached to the frame along the invert, and shall extend to the depth of the guide groove.

The fabricated gates shall be Waterman Model SS-250-1.

MATERIALS

Frames, Rails, Cover Slides, Yokes

Stainless Steel - ASTM A-240 and A-276, Type 304 or 316, as specified

Fasteners and Anchor Bolts

Stainless Steel - ASTM F-593 and F-594, Type 304CW or 316CW, as specified

Stems

Stainless Steel - ASTM A-276, Type 304 or 316, as specified

Flushbottom Seals

Rubber - ASTM D-2000 BC 615/625 Grade BE 625

Seats

Ultra High Molecular Weight Polyethylene (UHMW)

Finish

Mill finish on all stainless steel surfaces

SS-251-1-Y DIMENSIONS

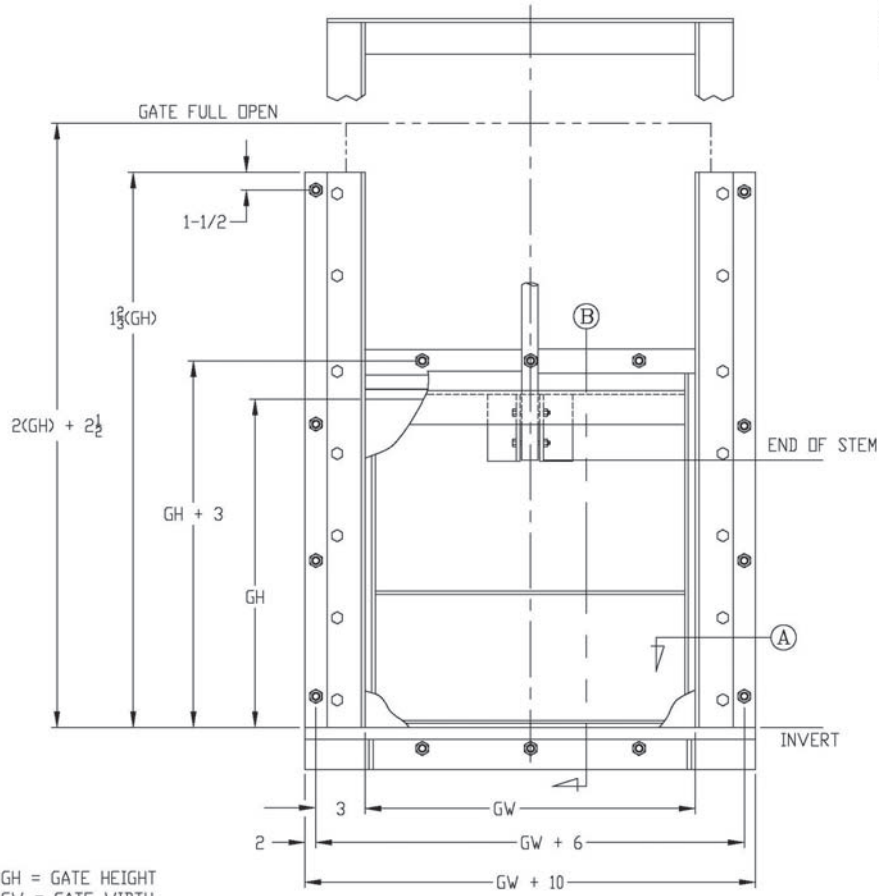

SS-251-1-Y

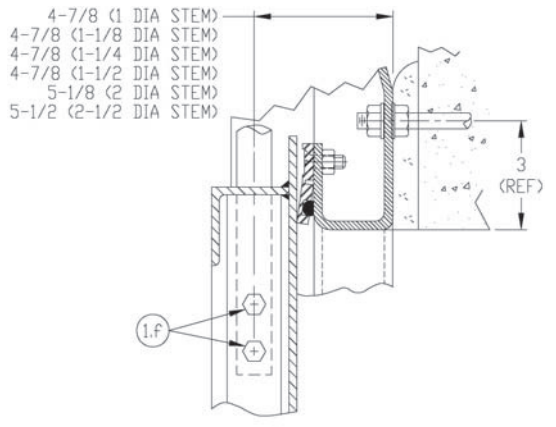

TOP RAIL SECTION

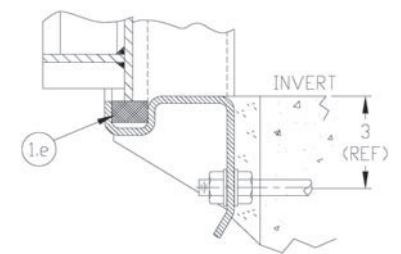

INVERT SECTION

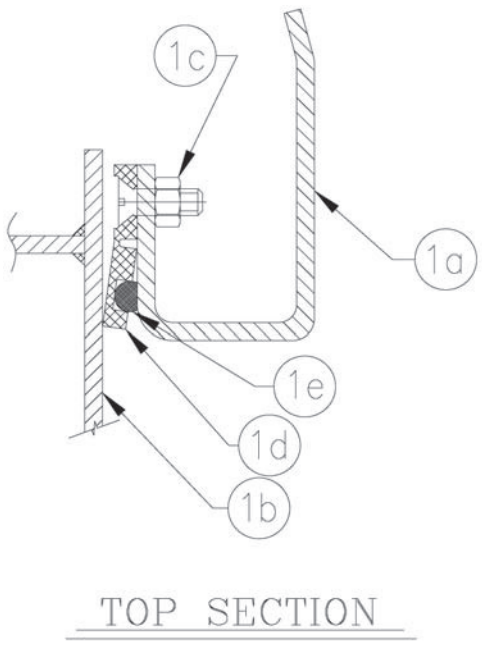

TOP SECTION

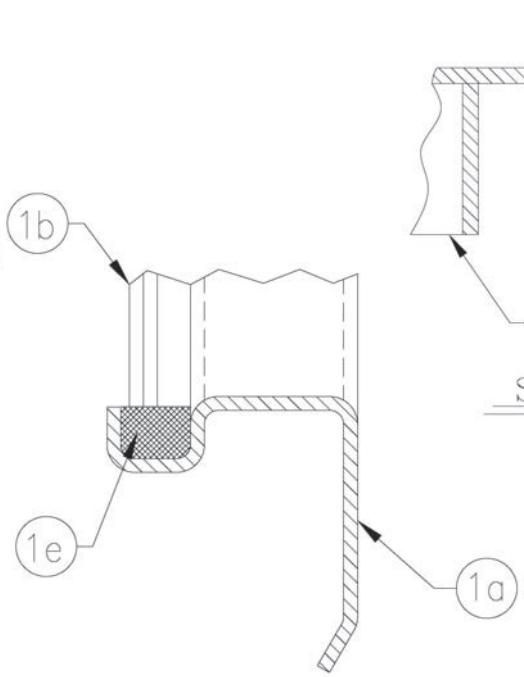

INVERT SECTION

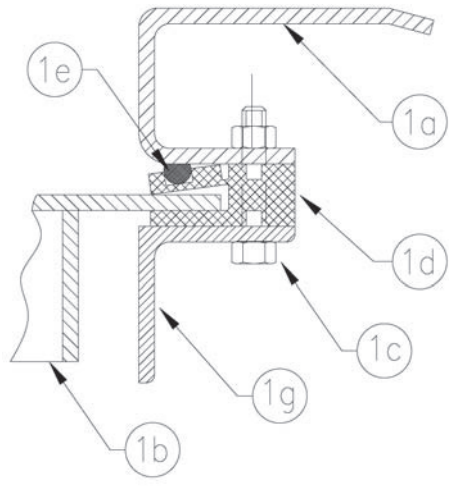

SIDE SECTION

PARTS LIST

NO.	NAME
1a	Frame Weldment
1b	Cover
1c	Assembly Hdwr.
1d	Guide Seats
1e	Seat
1f	Stem Bolt & Nut
1g	Retainer Bar

NOTE: FOR PRELIMINARY DESIGN PURPOSES ONLY
DO NOT USE FOR INSTALLATION
UNLESS PART OF CERTIFIED & APPROVED SUBMITTAL

SS-252-1-Y DIMENSIONS

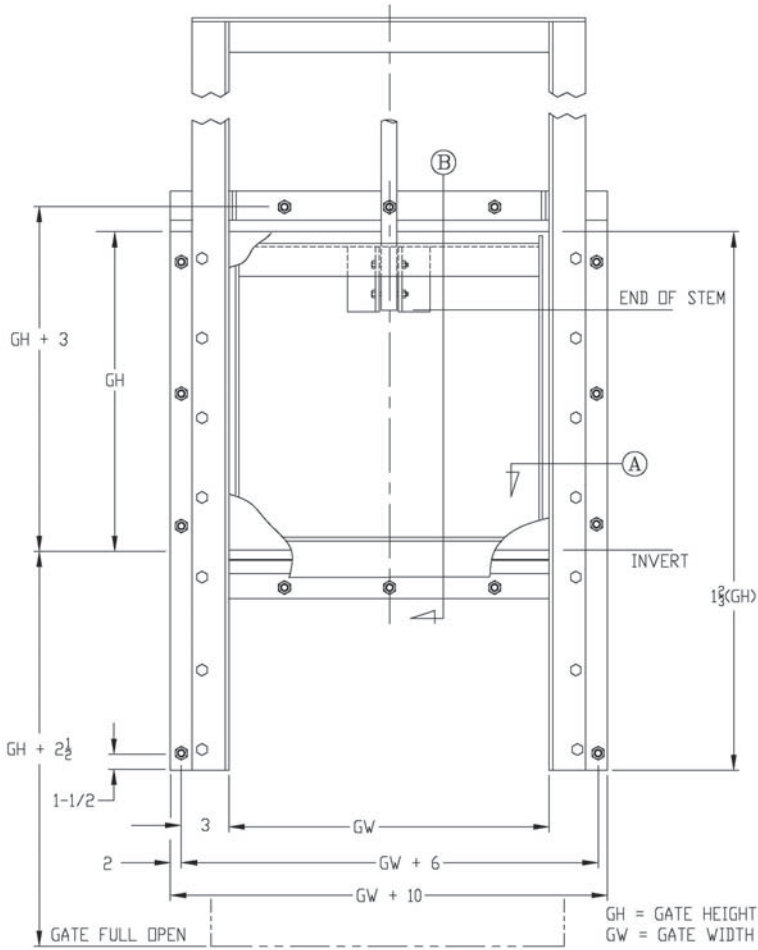

SS-252-1-Y

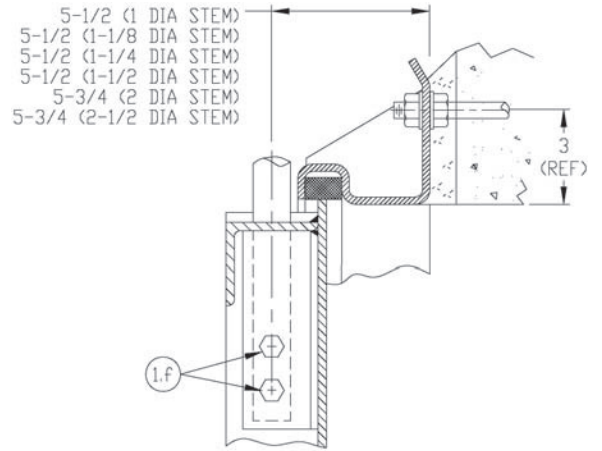

TOP RAIL SECTION

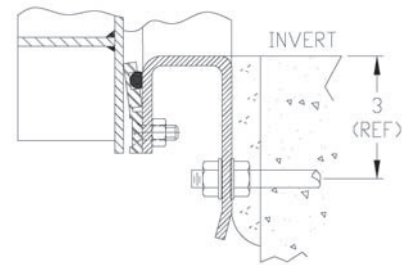

INVERT SECTION

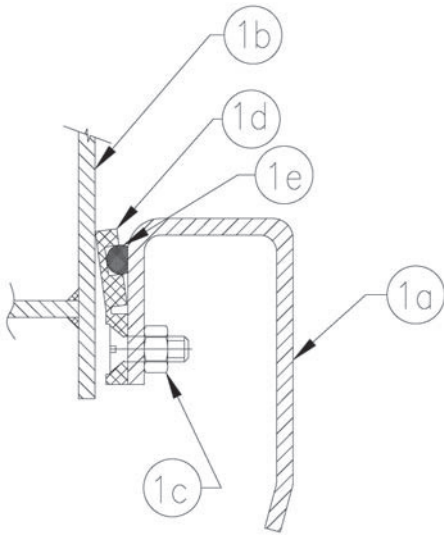

INVERT SECTION

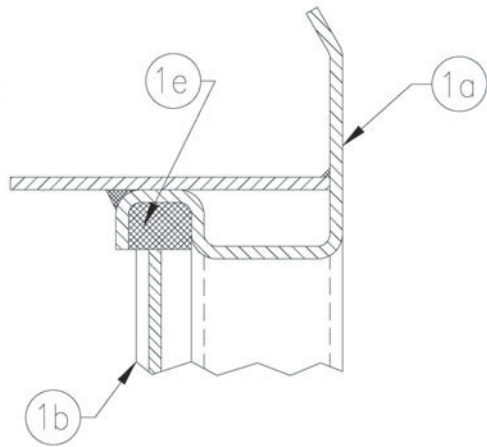

TOP SECTION

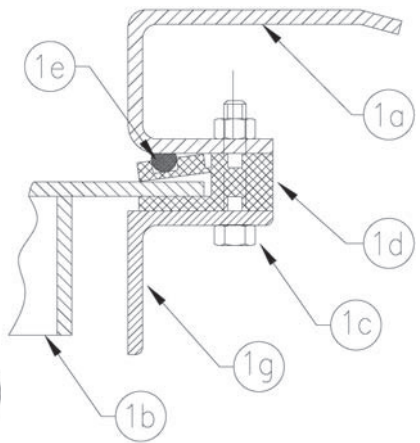

SIDE SECTION

PARTS LIST

NO.	NAME
1a	Frame Weldment
1b	Cover
1c	Assembly Hdwr.
1d	Guide Seats
1e	Seat
1f	Stem Bolt & Nut
1g	Retainer Bar

NOTE: FOR PRELIMINARY DESIGN PURPOSES ONLY
DO NOT USE FOR INSTALLATION
UNLESS PART OF CERTIFIED & APPROVED SUBMITTAL

SS-253-1-Y DIMENSIONS

- 4-7/8 (1 DIA STEM)
- 4-7/8 (1-1/8 DIA STEM)
- 4-7/8 (1-1/4 DIA STEM)
- 4-7/8 (1-1/2 DIA STEM)
- 5-1/8 (2 DIA STEM)
- 5-1/2 (2-1/2 DIA STEM)

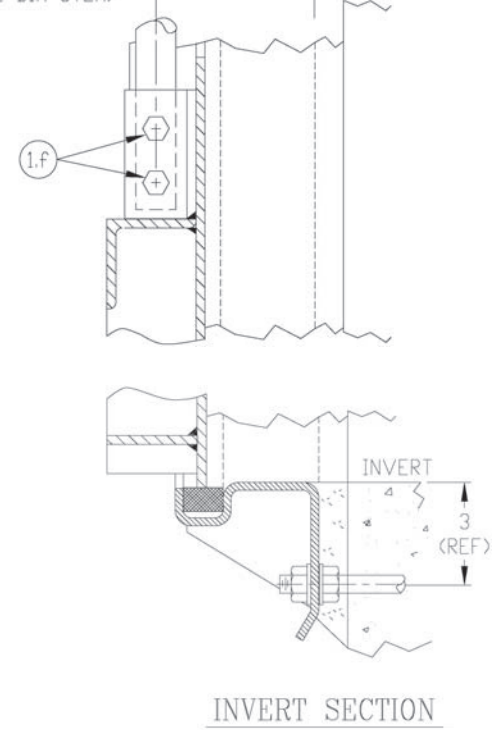
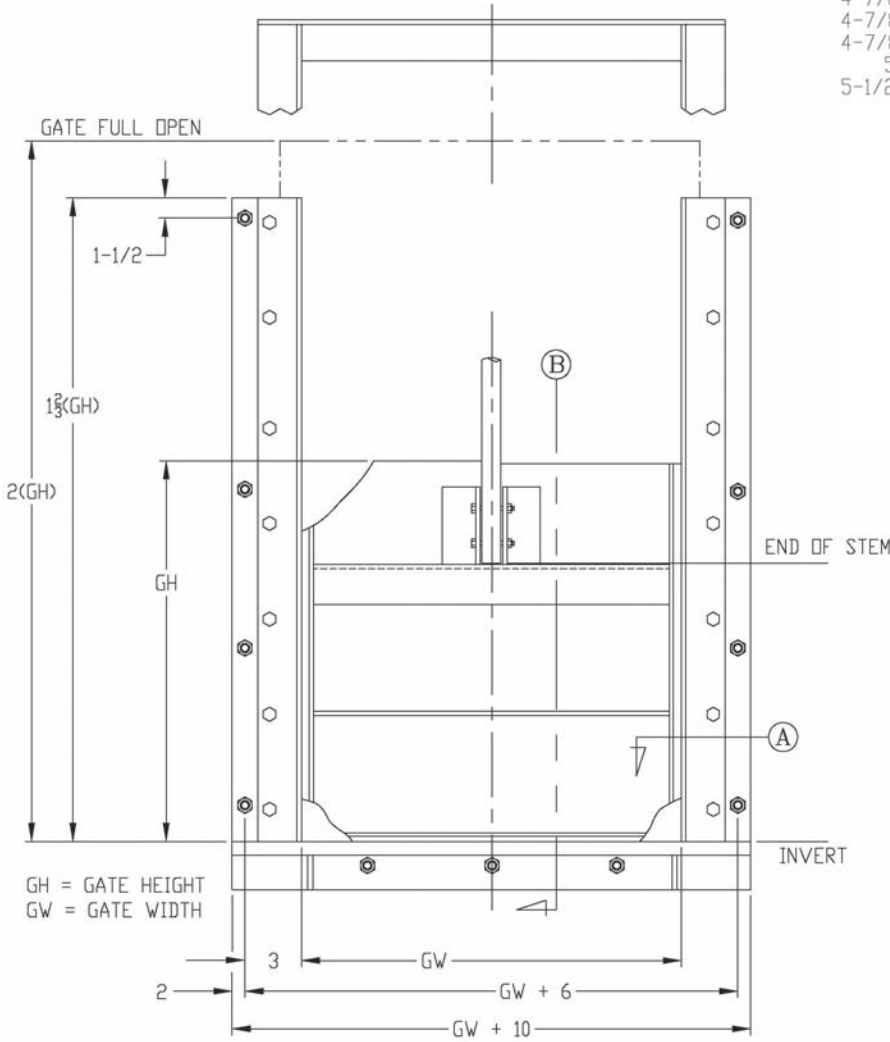

SS-253-1-Y

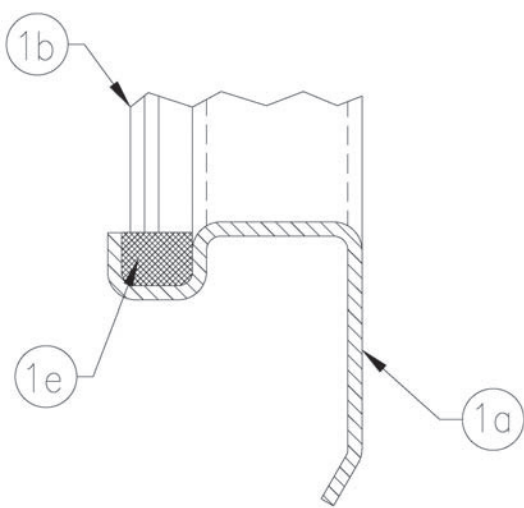

INVERT SECTION

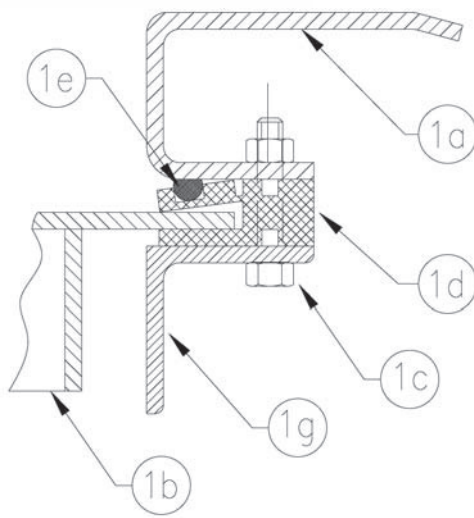

SIDE SECTION

PARTS LIST	
NO.	NAME
1a	Frame Weldment
1b	Cover
1c	Assembly Hdwr.
1d	Guide Seats
1e	Seat
1f	Stem Bolt & Nut
1g	Retainer Bar

NOTE: FOR PRELIMINARY DESIGN PURPOSES ONLY
DO NOT USE FOR INSTALLATION
UNLESS PART OF CERTIFIED & APPROVED SUBMITTAL



SS-254-1-Y DIMENSIONS

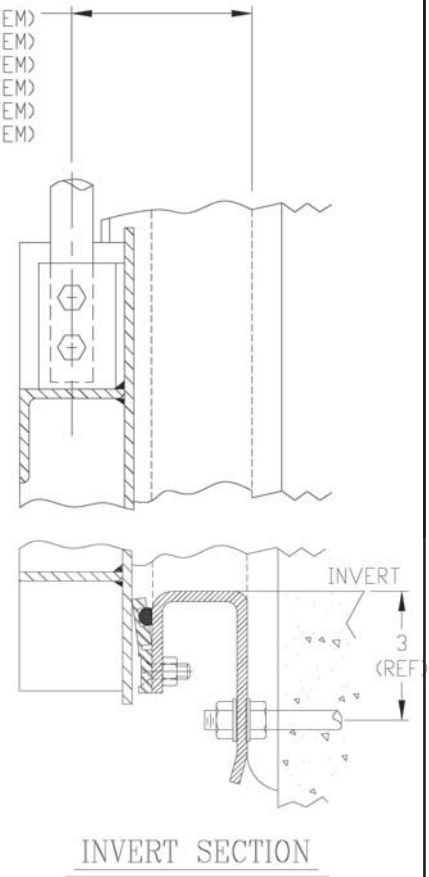
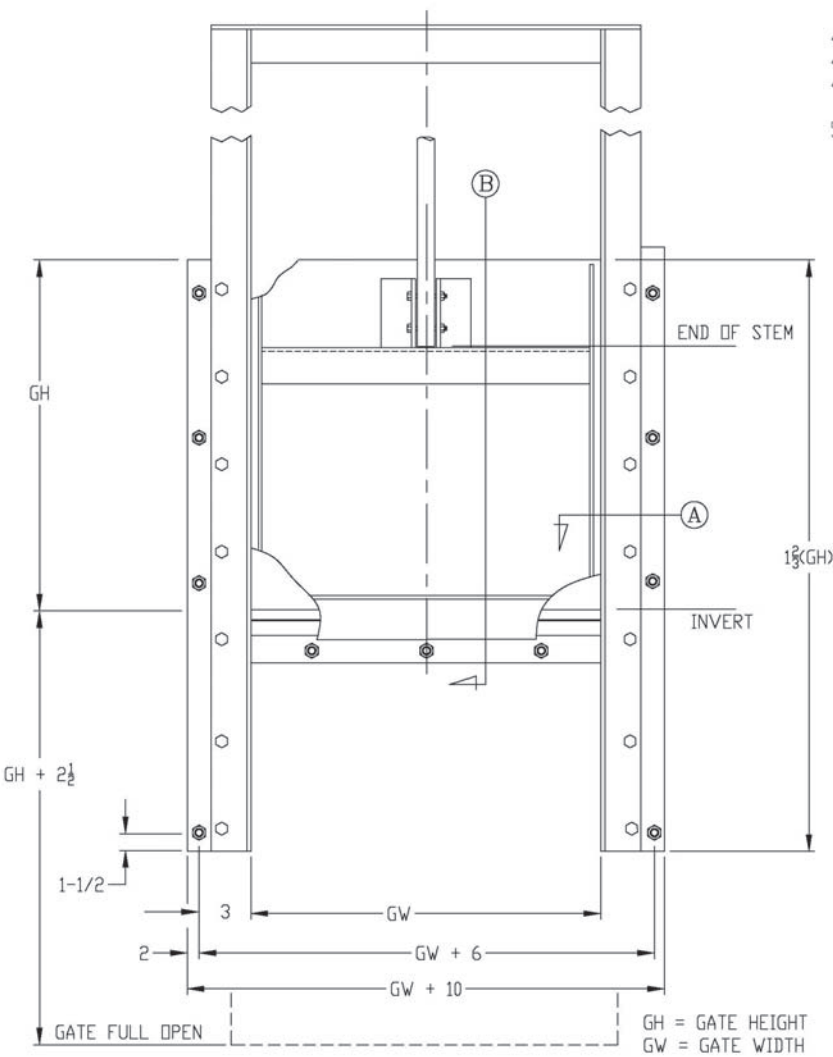

SS-254-1-Y

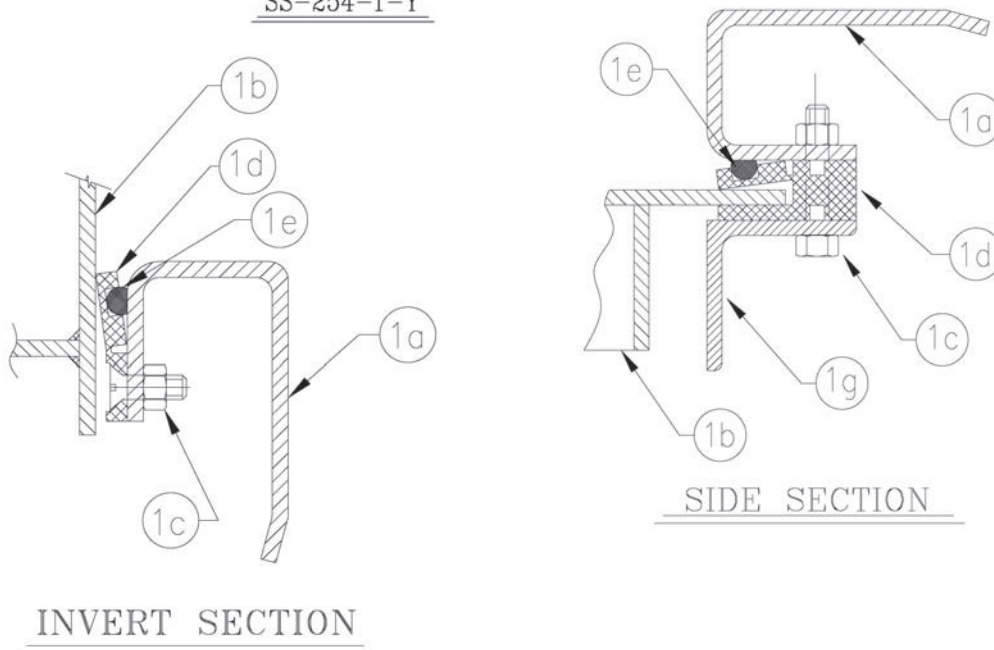

PARTS LIST

NO.	NAME
1a	Frame Weldment
1b	Cover
1c	Assembly Hdwr.
1d	Guide Seats
1e	Seat
1f	Stem Bolt & Nut
1g	Retainer Bar

NOTE: FOR PRELIMINARY DESIGN PURPOSES ONLY
 DO NOT USE FOR INSTALLATION
 UNLESS PART OF CERTIFIED & APPROVED SUBMITTAL