

MODEL VBG RECTANGULAR **BUTTERFLY VALVES**

Waterman rectangular rubber-seated butterfly valves are designed and manufactured for water-tight closure, ease on installation and operation, and adaptability to a variety of uses.

They are available in four-sided seating models for orifice or in-line mounting and in three-sided channel mounted units. Each gate is designed and fabricated for its specific installation and function requirements.

Uses and Criteria

Rectangular valves are commonly used where low headroom prevents the use of conventional sluice gates, and where flow regulating (modulating) is a requirement.

Other advantages include watertight performance in either direction (both seating and unseating heads), the acceptance of maximum heads of water on either side, and the ease of operation.

Applications include sewage treatment plants, water filtration projects, cooling tower basins, power plants, and many other water and flood control projects.

Pressure Ratings

Pressure ratings from 10 to 15 p.s.i. are available, and are suitable for both seating and unseating heads.

Sizes

Sizes currently available are 24" x 24" through 96" x 96". Larger and/or special sizes can be designed and fabricated to meet particular project requirements.

Waterman rectangular butterfly valves are completely shop assembled and tested before shipment.

Disc Design

The steel disc (vane) features an adjustable resilient seat with stainless steel fasteners and retaining bars. Made of Neoprene or Buna-N rubber, the seat seals against stainless steel for a positive, no-leak performance.

Adjustments of not less than $\frac{1}{8}$ " and field replacement are easily accomplished.

The streamline design of the disc minimizes turbulence in the full open position, lessens pressure drop across the valve in the open position, and provides excellent throttling characteristics.

Valve Body and Shaft

Standard valve bodies are fabricated from A-36 mild steel with flanges one side or two, as required for installation, and have a stainless steel seat.

The stainless steel valve shaft is keyed and bolted to the disc with stainless steel fasteners. Stainless steel tapered pins are available when required.

Packing glands are usually bronze with chevron-type packings. Sleeve bearings are self-lubricating. Thrust bearings are adjustable.



Operators

Waterman rectangular butterfly valves require a 90° turn of the disc to go from full open to full closed.

Manual operators with position indicator are available in worm-gear and traveling nut type with a handwheel, a chain wheel, or a 2" square operating nut for use with power devices.

Electric or hydraulic operators for local and/or remote operation can be provided.

Optional Accessories

Optional accessories include bonnet extensions, limit switches and integral controls for power operators.

Wall thimbles and anchor bolts are available.

**TYPICAL SPECIFICATIONS
MODEL VBG RECTANGULAR BUTTERFLY VALVES**

General

Rectangular butterfly valves shall be self-contained and of the rubber seated, tight closing type and capable of seating against the maximum head specified in either direction. Rectangular butterfly valves shall be as manufactured by Waterman Industries, Inc.

Valve Bodies

Valve bodies shall be rectangular and shall be fabricated from carbon steel conforming to ASTM A-36. The body shall be designed to be field fastened to a wall thimble, directly fastened with anchor bolts to a wall, grouted into a concrete channel, or double flange-mounted in a pipeline. Where a four-sided design is specified, the upper trunnion shall contain a stuffing box utilizing an adjustable bronze gland and square compression ring or self adjusting chevron "V" type packing.

Disc and Seat

The valve disc shall be fabricated from ASTM A-36 carbon steel and shall have a resilient seat recessed and clamped with a stainless steel retaining ring on to its periphery. The valve seat shall be field adjustable and replaceable. The design shall permit removal and replacement in the field without removing the valve disc, shaft, or valve actuator from their mountings. The valve seat shall not be interrupted by the valve shaft. Resilient seats shall be Neoprene or other special compounds as required.

A corrosion resistant metal seat area of stainless steel shall be incorporated in the valve body or disc and corner radii shall not exceed 4½ inches. (Alternately, the rubber valve seat may be mounted in body, with stainless steel seat on disc.)

Shaft and Bearings

Valve shafts shall be made of Type 304 stainless steel. The shaft shall be securely locked to the valve disc by means of stainless steel keys and bolts, or tapered pins as required.

Valve shaft bearings shall be self-lubricated sleeve type fitted into the valve body trunnion bore. The valve assembly shall be furnished with a fixed two-way thrust bearing designed to hold the disc centered in the valve seat at all times.

Operator and Support

An extension bonnet of fabricated steel shall be provided to locate operator as shown on plans and equally distribute operating torques and loads to structure. Operator shall conform to requirements of latest AWWA C-504, with sufficient capacity to seat, unseat, and maintain intermediate positions under the operating conditions specified herein.

MODEL VBG RECTANGULAR BUTTERFLY VALVES

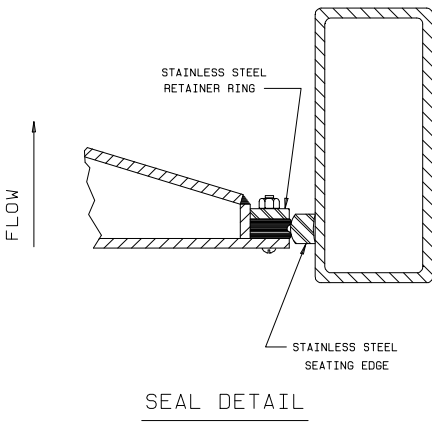
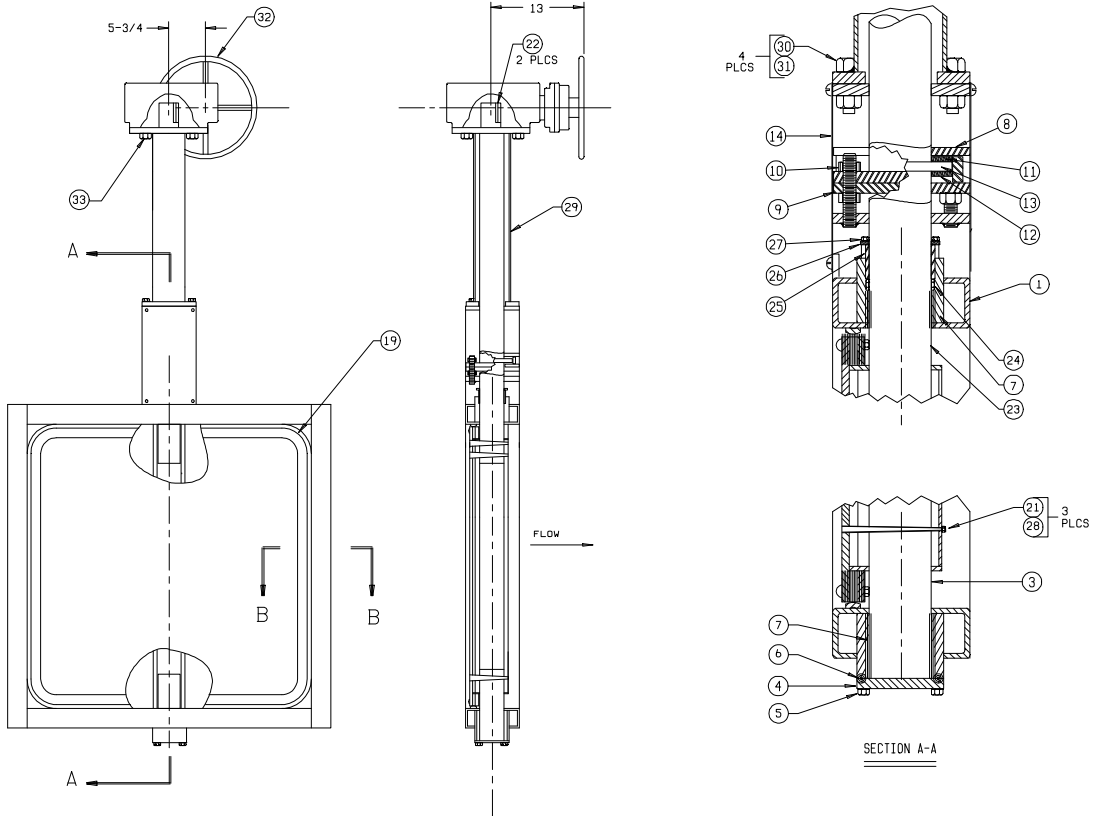

NOTE: RUBBER SEAT IS FIELD ADJUSTABLE AND REPLACABLE. WATER-TIGHT CLOSURE IS ASSURED FOR MANY YEARS OF SERVICE.

PARTS LIST					
No.	Name	No.	Name	No.	Name
1	BODY (stainless steel seats)	12	THRUST BEARING	23	UPPER STEM
2	DISC (vane)	13	SPRING PIN	24	PACKING
3	LOWER STEM	14	COVER PLATE	25	PACKING RETAINER
4	END CAP	15	SCREW	26	RETAINER PLATE
5	SCREW	16	RUBBER SEAT	27	BOLT
6	O-RING	17	RETAINER BAR (sides)	28	BOLT
7	BUSHING	18	SCREW	29	PEDESTAL
8	THRUST COLLAR	19	RETAINER BAR (corners)	30	BOLT
9	THRUST PLATE	20	SEALING WASHER	31	HEX NUT
10	HEX NUT	21	LOCK WASHER	32	OPERATOR
11	THRUST BUSHING	22	KEY	33	BOLT