

EM-25 PORTABLE ELECTRIC OPERATOR

- Heavy Duty Drill Motor
- Sturdy Tripod Stand Optional
- Optional Wheeled Tripod
- Auto Reset Type Overload Release Clutch
- Light Weight Unit for Maximum Portability
- Adaptable to almost any make Geared Lift

The Waterman EM-25 portable electric actuator is suitable for use with almost any type valve or gate utilizing a multiple turn geared input. Adapters are available for any type input shaft (square, half-round, splined, etc.) and the optional tripod support stand is height adjustable from 32" to 44" to accommodate most operator input heights. The motor is rated for 15 minutes continuous duty under full load, allowing full open-close cycle for most equipment. The EM-25 features a single phase motor, 110 volt, 60 cycle current and is reversible for easy open-close actuation. A 7.5 foot grounding type cord is furnished with the unit along with a torque handle for ease of operation.



TYPICAL SPECIFICATIONS FOR PORTABLE ELECTRIC OPERATOR

The Portable Electric Operator shall be a tripod-mounted, electric drill-type operator with a single phase motor designed for 110 volt, 60 Hz current and reversible operation. An automatically resetting clutch shall be provided to limit output torque to 75 ft/lb. An adapter shall be provided to allow use with geared gate operators with horizontal input shafts. The aluminum tripod shall be adjustable in height from 32" to 44". A 7.5 foot long grounded type cord shall be included. The operator shall be provided by the gate manufacturer and shall be Waterman Model EM-25 or approved equal.

EM-25 PORTABLE ELECTRIC OPERATOR

No.	Part
1	Electric Operator
2	Aluminum Tripod
3	Overload Release Clutch

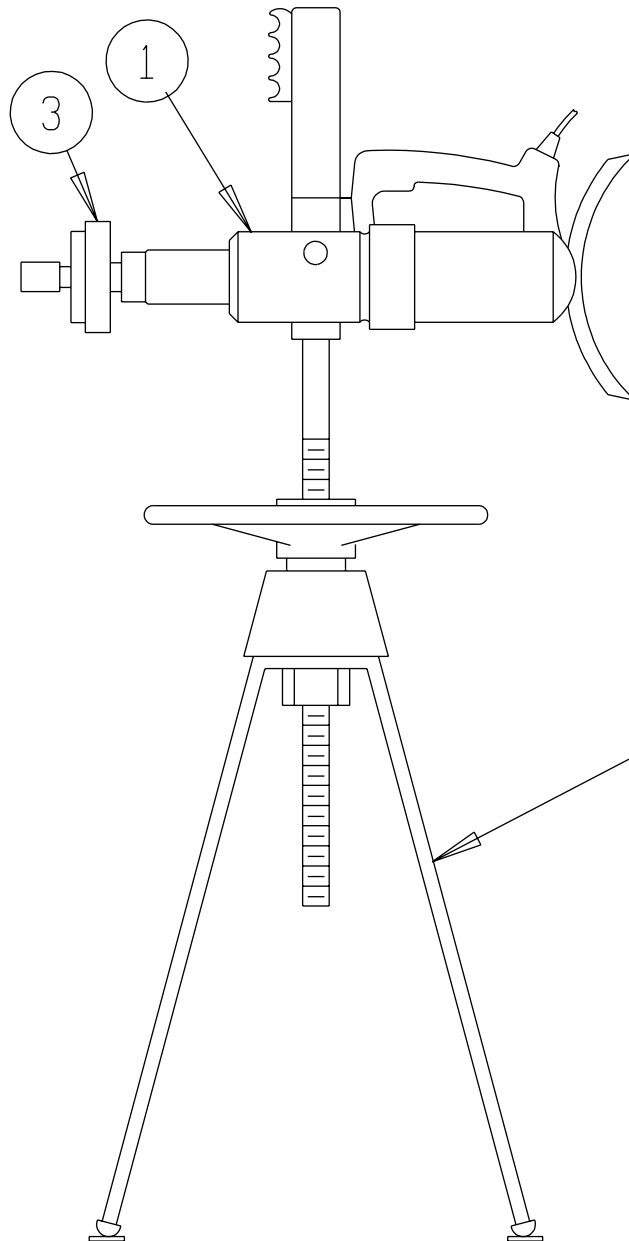

7.5 Ft. 3 Cond., 16 Ga. Cable
w/grounding type 3 prong plug.
Extension cord by others.

Notes:

1. Clutch rating 25 - 85 ft. lbs.
Shop set at 75 ft.lbs.
2. 2404-1 Specifications:
Max. torque - 4
Speed - 250 Max. RPM
Operation - Reversible
Power - 115 Volts AC 60Hz
Overall Length - 18.75"
Current Draw - 10 Amps @ full load
Power Required - 1200 watt @ full load
3. Weight - 70 lbs.